

VOL. XXXV. No. 2

FEBRUARY 1950

# MECCANO

## MAGAZINE

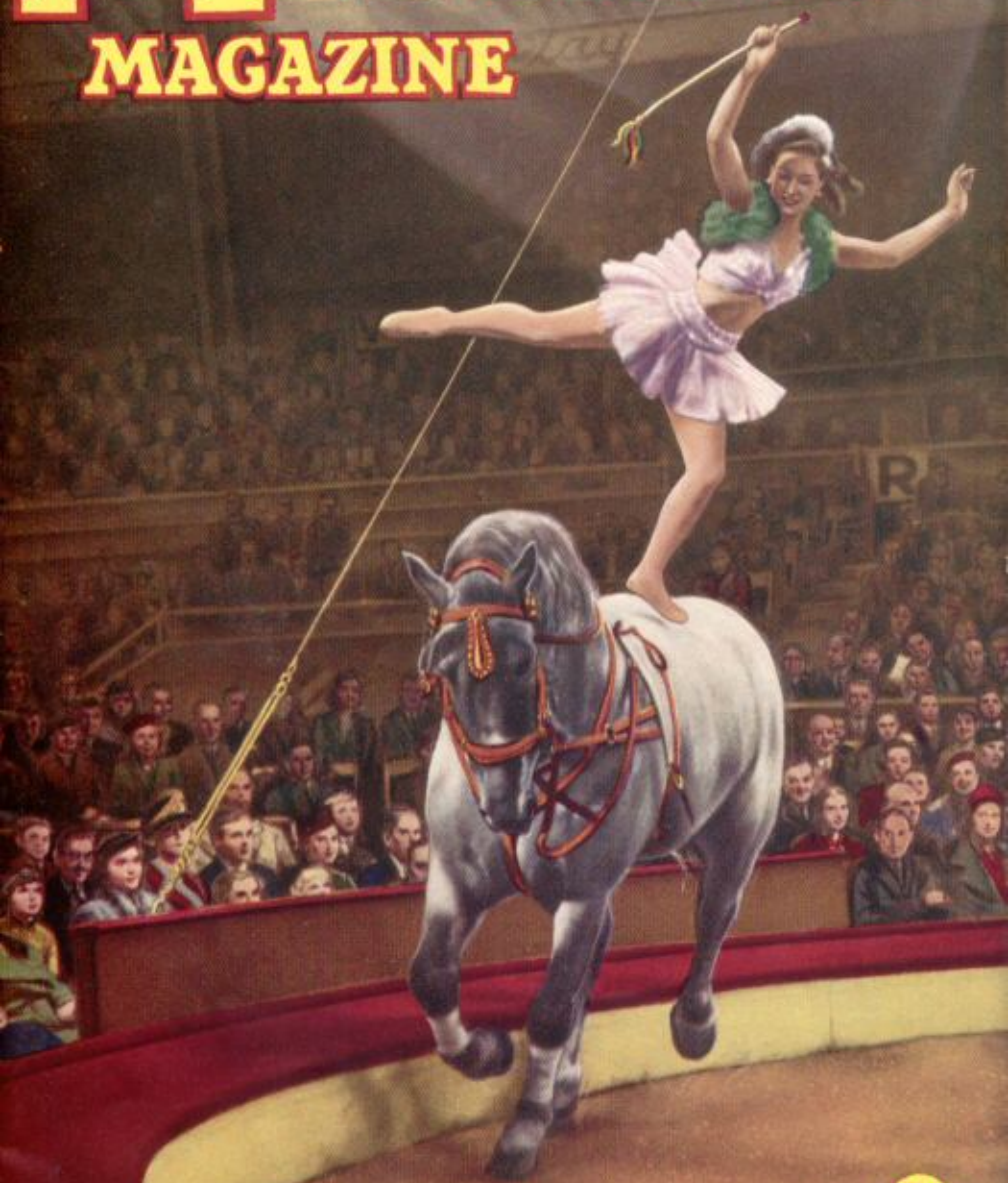

THE CIRCUS

9<sup>D</sup>

# DINKY TOYS



**Motocart  
No. 27g**  
Low loading three-wheeled  
truck. Tipping high-fronted  
body.



**Wheelbarrow  
No. 105b**



**B.E.V. Electric Truck  
No. 14a**



**The Standard "Vanguard"  
Saloon, No. 40c**



**Massey-Harris Tractor  
No. 27a**

**NEW**

Ready during the month



**Estate Car  
No. 27f**  
An attractive miniature of  
this popular general purpose  
vehicle



**Forward Control Lorry  
No. 25r**



**Ford "Fordor" Sedan  
No. 139a**



**Austin Devon Saloon  
Dinky Toys No. 40d**



**Harvest Trailer  
No. 27b**



**Coventry Climax Fork  
Lift Truck, No. 14c**  
The loading carriage is raised  
by turning a handle.



**4-wheel Hand Truck  
No. 105c**



**Loud Speaker Van  
No. 34c**



**Bedford Refuse Wagon  
No. 25v**  
Sliding covers, tipping mechanism,  
opening rear door



**Massey-Harris Manure  
Spreader, No. 27c**

For prices see current list

# SUPERTOYS



**Dinky Supertoys No. 571  
Coles Mobile Crane**  
Hoisting, jib-raising and slewing  
movements.



**Dinky Supertoys No. 562 Dumper Truck**  
Adjustable front wheels, tipping bucket,  
reversible driving seat.

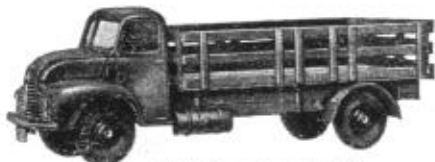

**Dinky Supertoys No. 531  
Leyland 'Comet' Lorry**



**Dinky Supertoys No. 514  
Guy Van**  
Large capacity van body, with  
opening double doors at rear.

**Dinky  
Supertoys  
No. 751  
Lawn Mower**



**Dinky Supertoys No. 504  
Foden 14-ton Tanker**

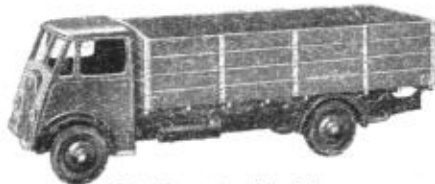

**Dinky Supertoys No. 511  
Guy 4-ton Lorry**



**Dinky Supertoys No. 563  
Heavy Tractor**

*For prices see current list*

**MADE IN ENGLAND BY MECCANO LIMITED**

# BRYLCREEM

to be sure . . .

**makes a tidy  
difference  
to your hair**

Let Brylcreem look after your hair and you're bound to benefit— for Brylcreem gives your hair this *double* benefit.

(1) **Day-long smartness** (2) **Lasting hair health**  
Besides setting the hair naturally, Brylcreem with its pure emulsified oils keeps the roots active and promotes natural hair-growth. Dry Hair and Dandruff soon become things of the past when you Brylcreem your hair. Ask for Brylcreem, it gives hair life.



County Perfumery Co. Ltd., Honeypot Lane, Stomors, Middx.

royds 65/38

## The Modern Hobby for MODERN YOUTH



Leading aviation designers of to-day learned much of their early knowledge by building and flying model aircraft: aeromodelling is a recognised R.A.F. hobby. Are you one of the hundreds of thousands now joining in this grand sport, hobby and pastime? No special skill is needed to start, no expensive workshop is required, just a few simple tools and you can begin. There are over 700 clubs in the country—club and individual contests and opportunities of representing your country in International Competitions. The illustrations show typical models you can build—either with their own miniature engines—like the real thing—or powered with rubber motors, or high-performance sailplanes. There is a model for all degrees of skill up to advanced radio-controlled giants of 12-ft. wing span.

To encourage would-be aeromodellers to make a start, we will send you, **FREE OF CHARGE**, a copy of the 64-page "AEROMODELLER"—the monthly magazine for all who build and fly their own models. Fill up the coupon below and send with a 2½d. stamp postage for your copy.



To AEROMODELLER (Dept. M.M.1.), The Aerodrome, Billington Road, Stanbridge, nr. Leighton Buzzard.  
I enclose 2½d. stamp for a **FREE COPY OF "AERO-MODELLER."**

Name .....

Address .....

LOOK  
AROUND



# Halfords



FOR EVERY  
ACCESSORY

THAT'S  
NECESSARY



★ OVER 220  
BRANCHES IN  
ENGLAND, SCOT-  
LAND & WALES  
★ THERE  
IS A HALFORD  
BRANCH IN ALL  
LARGE TOWNS

THE HALFORD CYCLE CO LTD  
*Head Office*  
239, CORPORATION STREET  
BIRMINGHAM, 4

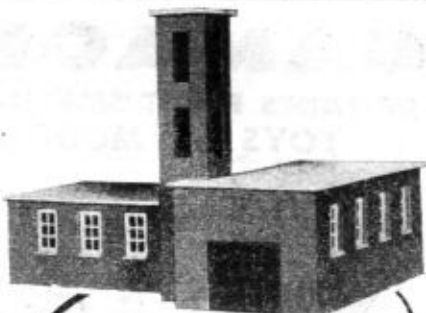

YOU can  
build this  
Fire Station

WITH

## BRICKPLAYER

BRICK & MORTAR  
BUILDING KIT

It enables you to build Houses, Garages, Railway Stations, Signal Boxes, or from your own Imagination. All railway models will fit "0" gauge scale. Buildings can be permanent, or dismantled by merely soaking in water and the bricks used again and again.

Enter for the  
**BRICKPLAYER COMPETITION**

Prizes of £10.10.0, £5.5.0 and £3.3.0, and a number of consolation prizes of Brickplayer Accessories will be awarded for winning models. Write for full details.

BRICKPLAYER KITS AT APPROXIMATELY 23/10 AND 44/- AND EXTRA ACCESSORIES ARE AVAILABLE FROM GOOD TOY SHOPS AND DEPARTMENTAL STORES.

If your dealer cannot supply, write for address of nearest stockist to:

**J. W. SPEAR & SONS LTD.**  
DEPT. M • ENFIELD • MIDDLESEX

# GAMAGES

BRITAIN'S FINEST SELECTION of  
TOYS and MODELS

An Entirely  
New Model

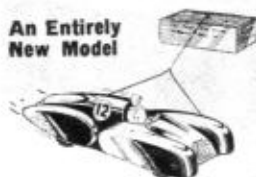

Complete with spare fuel charges. Length 6½ inches. Post and packing 9d. **17/6**

## Jet Propelled RACING CAR

Streamlined miniature Racer that achieves a speed of over 25 m.p.h. SAFE AND EASY TO OPERATE. Genuine dry fuel jet unit. Runs straight or tethered.

EX-U.S.A.

## ARMY BOX KITES

less than HALF-PRICE!

In brilliant eye-arresting Yellow material. Light-weight metal struts with spider bracing. 34 x 17 in. Folds very small. Easy to fly.

Formerly 24/9 PRICE **10/6**  
Strong Card 1/- extra. Post & Pkg. 9d.



GAMAGES, HOLBORN, LONDON E.C.1

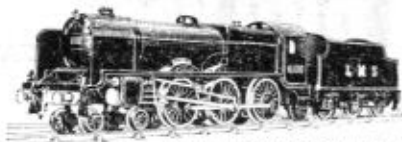

L.M.S. "ROYAL SCOT" No. 6100

## FASCINATING NEW MODELS

This beautifully finished ready-for-the-rails Gauge '0' Model of the L.M.S. "ROYAL SCOT" is one of our new range of Gauge '0' Models now available with either clockwork or electric drive. It is also one of the most famous engines of this famous class. Price complete (Clockwork or Electric) £16.0.0, Purchase Tax £3.14.11.

Our Gauge '0' Model Railway Catalogue (GO/17), containing further details of this and other locomotives, together with complete lists of Gauge '0' components, will be gladly sent on application.

Price 1/-

**BASSETT-LOWKE LTD.**  
NORTHAMPTON

London Showrooms: 112, High Holborn, W.C.1  
Manchester: 28, Corporation Street

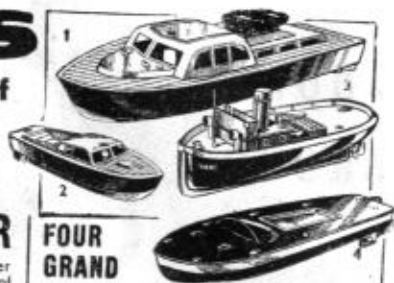

## FOUR GRAND CLOCKWORK BOATS

1. 11 in. **CRUISER**. A true-to-scale plastic cabin cruiser which has achieved great popularity. Beautifully moulded and detailed—including detachable dinghy. Post and packing 10d. **10/6**

2. 6 in. **CRUISER**. A miniature version of number 1. Perfectly finished. Strong motor. Post and pkg. 6d. **3/6**

3. **TUG-BOAT**. Length 7 in. The latest 'Penguin' scale model. Perfect details include lowering funnel. Post and packing 6d. **6/6**

4. **'TRI-ANG' METAL SPEEDBOAT**. Length 9 in. Strongly made. Bright Red/Blue enamel finish. Post and packing 6d. **4/3**

## VITALITY BULBS

FOR CYCLE DYNAMOS  
RADIO AND GINE/CAMERAS  
ALTHOUGH OUTPUT DOUBLED  
STILL IN SHORT SUPPLY



VITALITY BULBS LTD. NEVILLE PLACE, LONDON, N.22

**MORSE KEYS:** On a solid, polished wood base, with solid brass parts. Ideal for learners and practice on standard type keys, 3/6 each. **CRYSTAL SET COILS:** For M.W. on black moulded bakelite former and complete with circuit of complete set, 2/- each. **TUNING CONDENSERS:** .0005 mfd, solid dielectric, 5/-; .0003 mfd, solid dielectric, 5/-. These types are ideal for crystal sets. **RECEIVING CRYSTALS:** Permanent and Semi-permanent types, both 3/6 each. Separate crystals and cat's whisker, 6d, each plus post. **CRYSTAL DIODES:** These make excellent crystal sets and are far more sensitive than ordinary types, 4/- each. **CRYSTAL SETS:** De luxe type, looks just like Dad's Midget receiver, 16/- inc. purchase tax. Standard type, 10/11 inc. purchase tax. Both types needing only 'phones and aerial and earth to get results.

GOODS CAN BE SENT C.W.O. or C.O.D.

All goods are post free except where otherwise stated.  
**Vallance's** Vallance & Davison Ltd. (Dept. M.M.)  
144, Briggate, Leeds 1. Phone: 29428/9

**A GRAND PRIX Winner for YOU!**

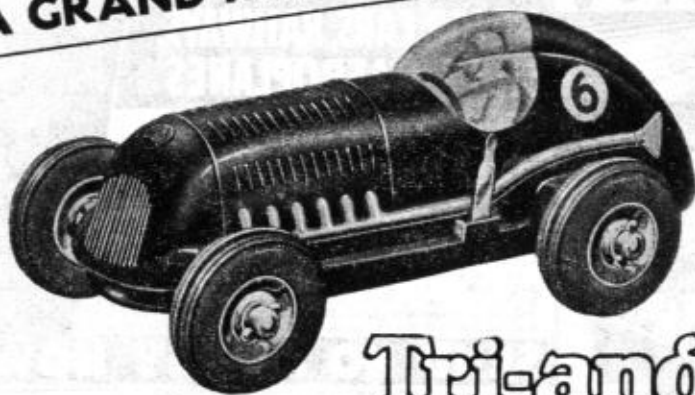

**Tri-ang**  
REGD TRADE MARK

**MINIC  
 CLOCKWORK  
 POWERED CARS**



L.S. 20 **MINIC Morris Minor**  
**2/3**



L.S. 20 **MINIC No. 2 Racer**  
**4/3**



L.S. 20 **MINIC British Railway Van**  
**5/6**

The engine roars, the starter's flag drops, you slam in the clutch and get off to a flying start with your MINIC No. 2 Racer. It's a car that has everything—brakes and a clutch, rubber tyred detachable wheels, and a transparent cockpit cover over a realistic racing driver. It is powered by a special long-running motor which gives a really fast run.

Get your Racer to-day and make it the start of a MINIC collection—there are over 70 models in the series.

**MINIC No. 2  
 Racer  
 8/9**

**GET THEM AT YOUR LOCAL TOY SHOP—we do not supply direct**

**Tri-ang  
 Toys**

**Lines Bros. Ltd.**

TRI-ANG WORKS - MERTON - LONDON - S.W. 19 - ENGLAND.

**Tri-ang  
 Toys**

# BOYS! GET THIS THRILLING BOOK OF HIGH-SPEED MARVELS

## THE COMPLETE BOOK OF MOTOR CARS, RAILWAYS, SHIPS & AEROPLANES

### YOURS at Amazing Privilege Price!

Hurry for this super book! New, exciting, different! The greatest book of its kind ever seen! 384 pages reveal inside story of modern high-speed transport. Amazing super-jet aircraft, sensational racing cars, mammoth ocean liners, giants of the world's railways, over 300 illustrations. Nearly 100 "how-it-works" drawings. Stocks limited! Order NOW! Satisfaction or money back guaranteed. Standard edition, bookcloth, 5.6. De Luxe, leather-bound, 9.5. Prices inc. post., etc. **ACT NOW!** Fill in Reservation Form below. Post in 1d. stamped, unsealed envelope to Book Dept. X.Y.I., The People's Home Library, 49 Neal St., London, W.C.2.

**384 PAGES**  
OVER 300  
ILLUSTRATIONS  
including  
**NEARLY 100**  
**"HOW-IT-WORKS"**  
DRAWINGS

## SEND NO MONEY NOW!

Reserve for me "THE COMPLETE BOOK OF MOTOR CARS, RAILWAYS, SHIPS AND AEROPLANES," in the edition shown, and send my privilege certificate and invoice. Cross out edition NOT required.

(a) STANDARD (b) DE LUXE (Use Block Letters)

Name .....

Post Postal .....

Address .....

FIRMLY AFFIX  
1d. STAMP HERE  
to bring Privilege  
Certificate Invoice  
with FULL SATIS-  
FACTION OR MONEY  
BACK GUARANTEE

Other open in U.K. and Eire only, closes Feb. 28th.

N.Y.I. (L.S.A.) Feb. 50

## SOMETHING NEW!

FOR 40 YEARS we have specialised in "0" Gauge Electric Model Railway Equipment with special regard to the requirements of the individual builder of lay-outs as against table-top outfits.

NOW

**A COMPLETE BOXED MODEL RAILWAY with a SMOKING LOCO.**  
**SMOKE** from slow to full speed emerging in **SYNCRONISED PUFFS**  
and controlled by a **Cut-out Switch**

**NO PILLS - NO TIRESOME CLEANING - NO CONSTANT REFILLING**

The Apparatus is a real Engineer's job totally enclosed in the Loco. and powered by the wonderful 12 Volt D.C. Motor (standard in our most expensive models) which has given up to 20 years continuous use in many, many cases. Will run on Dry Batteries, Accumulators, or trickle chargers.

**ALL THE FOLLOWING AT THE PRICE OF A SINGLE HAND BUILT LOCO.**

- Hand Built, painted and Transferred 0-4-0 Saddle Tanker.
- Two 12 ton covered Vans, correctly Coloured and detailed.
- One 12 ton open Wagon true to type.
- 15 ft. of Three Rail Track, mounted on Wood Sleepers with Detailed Chairs supported on full length Batters.
- Lined **Presentation Box** covered in Brown Leatherette.
- Plans for extending Layout.
- Illustrated Catalogue printed on Art Paper.
- Comprehensive Guarantee for One Year.

**PRICE—Without Smoke Apparatus £12.4.5 including Purchase Tax**  
**With Smoke Apparatus £13.15.0 including Purchase Tax**

Please note that we do not supply direct to the Public but we have Agents in all principal towns. They are Model Railway Experts who are at your service at all times. Addresses on request.

**THE LEEDS MODEL COMPANY LIMITED**  
**POTTERDALE MILLS, DEWSBURY ROAD, LEEDS 11, ENGLAND**

(Our Overseas friends are asked to note that the prices given include U.K. Purchase Tax and Retailers' Margin. Write for c.i.f. prices).



# S.E.L.—indoors and out!

Models and power units for your model workshop, and Pocket Binoculars and Telescopes for sports, scouting, camping, and all outings! It is worth your while to ask for S.E.L. Precision Quality Products at your dealer's because they are unrivalled in their power to give you thrills and interest.

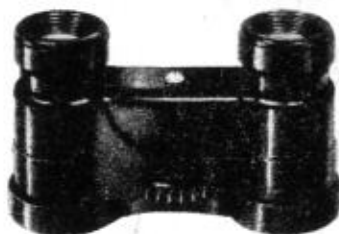

**Pocket Sports Binoculars**  
Size 3½ in. x 2 in. x 1½ in. Weight 4 oz.  
17/6 No tax

Also Theatre Glasses, 40/6 No tax  
and Sports Glasses, 42/9 No tax

**Major Steam Engine (below)**  
Base 6 in. x 5½ in. Height 4½ in.  
47/5 Inc. tax

Also 3 smaller steam engines:  
35/7, 30/11, 24/11 Inc. tax

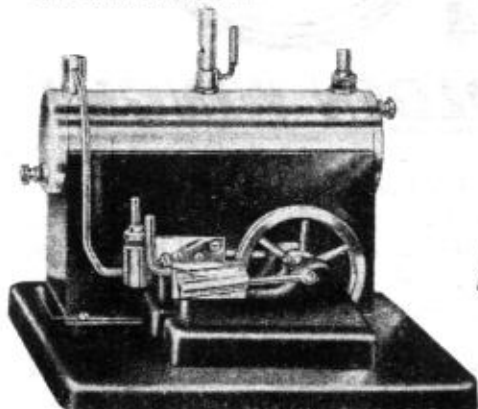

See them all at your dealer's. Write for illustrated list to

## SIGNALLING EQUIPMENT LTD

(Dept. 3), Merit House, Potters Bar, Middlesex



**Railway Signal No. 1**  
Height 8½ in.  
27/6 Inc. tax. Also  
Lighthouse 17/6 Inc. tax



**Traffic Signal No. 2**  
Height 7½ in.  
22/6 Inc. tax. Also  
Traffic Signal No. 1  
21/- Inc. tax.



**4-Section Plastic Telescope**  
Size closed 3½ in.,  
open 8½ in. 6/6 No tax.  
Also smaller telescope,  
5/- No tax



**Tool Set No. 2**  
Box size 12½ in. x 14 in. x 1½ in.  
18/- No tax. Also larger Tool Sets:  
No. 2/A, 25/- No tax, and No. 3, 36/-  
No tax.

**IT'S A BEAUTY!**

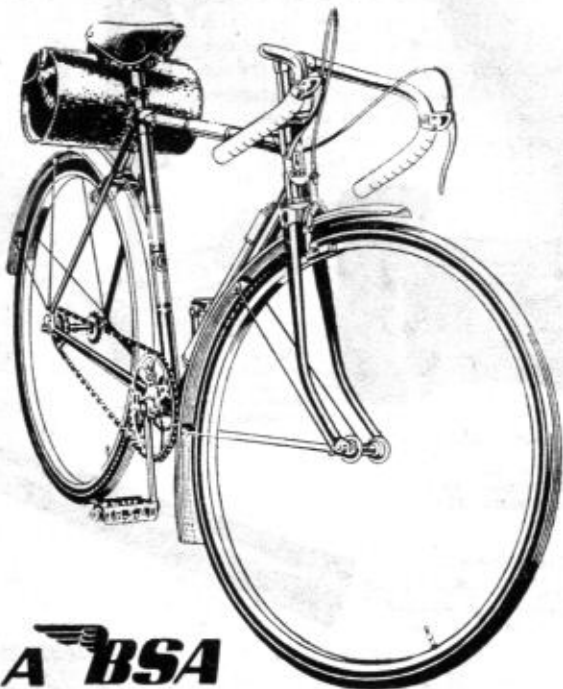

**IT'S A *B*SA**

**GOLDEN WINGS!**

**T**HIS is the bike that *really* stands out from the rest! It's got a silver head and silver bands, and a beautiful blue finish. Suppose you had one of your own—imagine how you'd flash along in front of all your friends! This is the smart, *speedy* bike you've always wanted!

**IT'S TIME YOU HAD A *B*SA**

**FREE!**

B.S.A.'s exciting fully illustrated catalogue.  
Send us a postcard. This is the address: just

**B.S.A. CYCLES LTD., 31, ARMOURY ROAD, BIRMINGHAM 11**

# MECCANO

## MAGAZINE

Editorial Office:  
Binns Road  
Liverpool 13  
England

Vol. XXXV  
No. 2  
February 1950

With the Editor

### Cab Comfort for Enginemen

The British Railways photographs reproduced on page 61 of this issue, showing the proposed arrangement of cab and footplate for B.R. standard locomotives, reminded me of some of the pictures of the driving arrangements of the locomotives of the earliest days of railways. Then, and for many years afterwards, engines really had no cab at all, and the footplate arrangements were extremely crude. It is quite evident that the early designers thought only of their engine and its pulling power and had little consideration for the comfort of the driver.

On some of the earliest engines the driver rode on an unprotected platform perched up at one side of the boiler, while his mate fired the boiler from the open front of a very elementary tender. Even when the footplate as we know it had become a feature at the fire-box end of the engine, the men were still fully exposed to the weather. There might be side panels to their footplate, or they might have merely a more or less ornamental railing; but there was not even a weatherboard to ward off wind and rain when on the run.

It is difficult to imagine the feelings of a present-day top-link driver if he were asked to work under such conditions.

When the cab did develop from the weatherboard by the addition of side panels and a roof, it was all too often a very skimpy affair. The roof was short, and the side openings were such that little real protection was afforded.

Old engines are still in use to-day on which it is possible to see, on stormy days, a sheet stretched from the cab roof to some point on the front of the tender. This is not a convenient arrangement, but it is better than nothing if there is

tender-first work to be done. How much better it is to have a properly-designed cab with extended roof, and a tender front that gives protection.

Control arrangements on the early engines seem to have been extremely simple. There would be a plain steam valve to start the engine, one or two cocks and handles but no engine brakes, no pressure and water gauges, the injector had not yet arrived, and continuous power brakes and steam heating for the train belonged to the distant future.

### This Month's Contents

	Page
Bertram Mills Circus .. ..	50
by Halgar Harte	
Rubber-Tyred Trains in France ..	53
Some Unusual Models .. ..	54
by W. J. Bassett-Lowke, M.I.Loco.E.	
Making Escalator Handrails Fit ..	55
by T. R. Robinson	
Sugar from Beet .. ..	56
by W. H. Owens	
Pennine Way .. ..	62
by Arthur Nettleton	
World's Biggest Refrigerator ..	66
by John W. R. Taylor	
Luxury Bus Travel in South Africa ..	69
by Frank Dickinson	
Great New Zealand Power Scheme ..	72
"A.T.C." on the Southend Line ..	74
by J. Brooks	
Using the Meccano Gears Outfit ..	78

Air News, 70. Books to Read, 58. Club and Branch News, 84. Competitions and Results, 92-3. Fireside Fun, 95. From Our Readers, 77. H.R.C. Pages, 85-7. New Meccano Model, 82. Among the Model-Builders, 89. Model-Building Competition, 83. Photography, 65. Railway Notes, 60. Stamp Pages, 88, 91.



The End of the Act. This and the next three photographs, and the one on which our cover is based, show scenes at the Bertram Mills Circus at Olympia, London.

## The Bertram Mills Circus

By Halgar Harte

Photographs by Lancelot Vining, F.R.P.S., F.I.B.P.

**G**LAMOUR, spangles, tinsel, sequins—these are the traditions of the circus. Add thrills, laughs, cavorting horses, juggling sea-lions, ballet-dancing elephants, pretty ladies suspended from lofty trapezes, and you have the complete recipe.

That is the front of the "house." Let us look behind the scenes. First there is the world search for new talent. In every capital in the world there is a circus agent, on the look-out for novelties to recommend to the proprietors of hundreds of circuses, large and small. Every year for some four months Mr. Cyril Mills, joint managing director, with his brother Bernard, of the biggest circus in Europe, sets out on an expedition of discovery.

Last year, between April and September,

he covered over 35,000 miles by air, often in his own aeroplane. Twice across the Atlantic and a double journey across the American continent, he saw over 100 circuses; on the Continent, he attended 40 more. His total bag was seven acts new to Great Britain, but he looked upon each as a contribution to the prestige of the circus founded by his father in 1920.

Incidentally, the late Bertram Mills started in the circus business on a bet with a famous titled sportsman. They visited a circus together and at the end of the show Mills remarked: "If I couldn't put on a better show than that, I'd eat my hat." The nobleman took up the challenge, remarking: "Right, I'll take you on that. When do you start?"

Within a year Mills, a coach-builder, started getting his show together. He scoured Europe and America for turns and launched the hazard in a blaze of success. Apart from the war period, the Mills circus has been an annual event at Olympia.

Organising a circus is not all smooth going. It entails the most scrupulous care in choosing the right kind of staff and administrative entities. At Olympia there are 200 employees, comprising ringmen, grooms, carpenters, electricians, painters, designers, mechanics, trainers, typists, clerks, accountants—

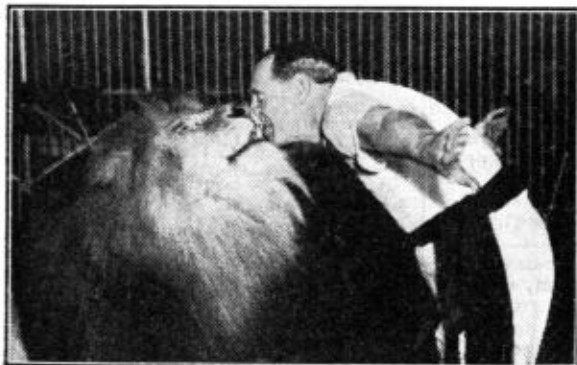

A Daring Act.

quite apart from those who provide the entertainment.

When the tenting company and staff come off the road as they did in Mid-October in 1949, at the end of a 28-30 weeks' tour covering about 2,000 miles, the elephants, horses, lions, wagons, caravans and permanent staff go into Winter Quarters at King's Ride, Ascot. There, quite near the famous racecourse, the community start to prepare for the Olympia season. Everything has to be refurbished. This done, new elephant and horse displays are practised daily in replicas of the ring at Olympia. There is a special ring, with cage surround, for putting the lions and tigers through their paces. The costume designer goes to work with the aid of half-a-dozen seamstresses. Ring attendants, male and female, are measured and fitted for their new costumes; the electricians work out new schemes and the wheelwrights test all the vehicles for wear and tear on tyres. For a couple of months the Winter Quarters is a hive of industry. No minor element is overlooked. Even the ropes and canvas are put through tests.

Then comes the day of migration to Olympia, about a week before the opening date. There the rehearsals continue, while a horde of workers fix the canopy, seating, dressing-rooms, stables and myriad paraphernalia.

It has been the rule for many years to admit to the two dress rehearsals on the day before the public opening, some 13,000 children from schools in the poorest parts of London. The performers, particularly the clowns, approve enthusiastically of this arrangement, since they know that if the youngsters approve, the show will pass muster.

There are certain essential stand-bys in circus presentation. One must have horses, elephants and clowns. These are basic. What is built on that foundation depends

on the quality of the performers and the presentation of the whole. Cyril Mills is not only the discoverer of talent, but the "stage" director. He it is who works out the order, timing and continuity plan by which there shall be no delays and smooth working is assured. The timing of a circus programme means, of course, also timing the clowns in their various entrees and performances. The funny men are kept just as much to a strict tempo as the elephants and horses.

The elephants, by the way—six of them, all females—are in the proprietorship of the Bertram Mills Circus. They have been a dozen years or more with the same trainer, John Gindl, who knows their every whim. Talking of whims, elephants are just as prone to idiosyncracies and pranks as any other performing animal. Gindl's lot are occasionally prankish, but only when he is outside their immediate orbit, which is rarely. The leader, Jenny, takes it into her head sometimes to put the other elephants out of step, but her performance as one of the "awkward squad" is instantly corrected by one word from the trainer. He knows them all by their own names, some of which are Indian and the others less oriental.

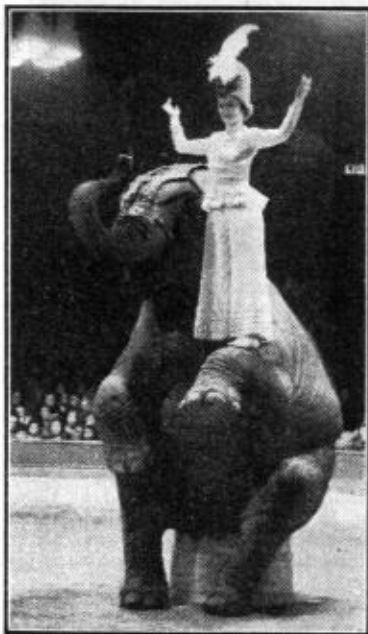

One of Gindl's Elephants.

During the time they have been with Gindl, they have learned to play their own version of cricket, to perform on various musical instruments, and to engage in a ballet and also a mock battle.

Such acts as performing sea-lions and performing polar bears are usually self-contained units which travel about the world. Bertram Mills possesses a group of lions, which they do not put into every season's programme, so as to vary the entertainment.

When it comes to selecting horses and training them the process can be very irritating. To obtain a perfectly-matched dozen of chestnuts suitable for ring work, Mr. Bernard Mills, who is a great horse



Polar Bears do their stuff.

authority, may have to buy as many as twenty, since some of the horses which are the right colour, height and weight may not apply themselves very willingly to the circling gyrations expected of them. When a horse has been bought and his training begun, and he shows no inclination for the work, he is disposed of and a substitute obtained. In the days before the war Mr. Bernard Mills used to buy most of his circus horses from Poland, where the particular type he sought were the vogue. In Poland the army horses conformed pretty accurately to the needs of the circus and the best performing horses came from that source.

In the Bertram Mills Circus there is a donkey called Erebus, who has travelled the country since being presented to the Bertram Mills management by the Mayor of Middlesbrough. When he was accepted he showed a need for companionship, and it was not until they purchased a llama that he was mollified. Now they are such great friends that if by chance the llama strays, Erebus brays his head off in protest. On the other hand, the llama creates a disturbance every time little Erebus is missing. They are inseparables.

The flying gymnasts come from all over the world. There was a time when the English acrobatic families

supplied the Continent and the United States with thrills, but now the product has become more general, and nowadays one may secure an ace company of trapeze artists in almost every important city in the world, with the exception of Russia, where circus performers of all kinds, irrespective of their original nationality, are forbidden to move out.

Every year the Bertram Mills Circus goes into the Provinces after an interval, following the Olympia show. They cut the country

into three parts and tour each in turn. This year, from about April, the circus will be on the road in the North of England and possibly as far North as Aberdeen. The Midlands is the first area, then South and West the third. Nearly 200 people travel with the show when it is on tour. These include grooms, ring-workers, carpenters, electricians, wheelwrights, painters and mechanics of various kinds. In these days, the tenting circus travels by rail. Huge trucks house the elephants and horses and the people who normally live in caravans travel by the same method, but still within the caravans.

In their winter quarters, 150 people are housed as though it were a village. The huge "big-top" tent, smaller tents, 20 odd caravans, are all put under repair and everything is refurbished.



Clowns and children always get on well together.

# Rubber-Tyred Trains in France

**I**N the article "The Railways of France" in the December 1949 "M.M." reference was made to the introduction of a train running on pneumatic tyres instead of

normal construction, was made more easy by the use of pneumatic tyres. They insulate the bogie frames and the body from constantly recurring shocks and short-period vibrations and therefore allow smaller metal sections to be used in the construction. In addition they eliminate the characteristic rail-joint noise, with a consequent simplification in the sound-proofing of the body.

The frames for each of the three train sets embody three different methods of construction in order to provide information regarding their relative value. In one train welded stainless steel is used, another employs aluminium alloys and riveting and the third is built up of ordinary mild steel by means of electrical resistance welding. Each train set is fitted with bogies of the same type.

Each coach can run for some time without slackening speed even if a tyre is punctured. This is made possible by the use of a system of compensating bars which spread the load over the other axes if one is running on a flat tyre.

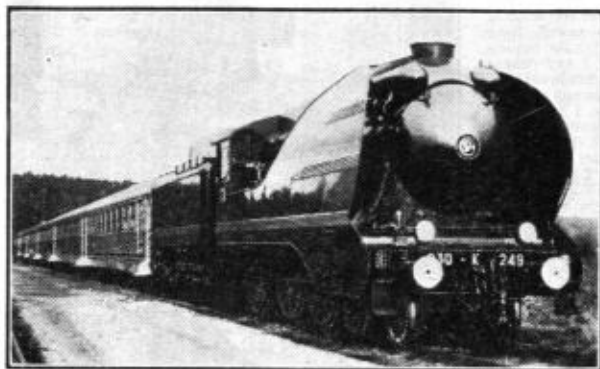

The experimental French train made up of vehicles running on rubber tyres. The photographs and information on this page are by courtesy of S.N.C.F. (French Railways).

the usual steel-shod wheels. The first railway vehicles to be mounted on pneumatic tyres were railcars built by the Michelin Tyre Company. These cars became known as "Michelines," and the experience gained in running led to the idea of equipping a locomotive-hauled train with such tyres. Construction was delayed by the war, but the first three trains for high-speed day service between Paris and Strasbourg were completed some time ago.

Six coaches make up each train, including a dining car and a buffet car. The vehicles are air-conditioned and have fluorescent lighting. The complete train carries 73 first-class and 176 second-class passengers.

With pneumatic tyres, the weight per axle must not much exceed two tons; so these vehicles must be light and carried on a relatively large number of axles. Each coach in these trains weighs only 21 tons loaded and is carried on two five-axle bogies. The problem of arriving at the correspondingly low tare weight of 17 tons, which would have been insoluble with coaches of

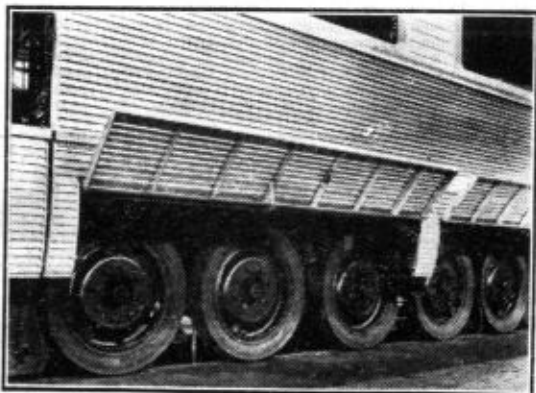

A five-axle bogie unit with rubber tyres. Normally these are partly hidden by the inspection covers that are shown opened up in this illustration.

## Some Unusual Models

By W. J. Bassett-Lowke, M.I.Loco.E., F.R.S.A.

WE are all familiar with model railways, model sailing ships, power boats and aircraft, and with the various types of models used for window displays. Not so many of us, however, have opportunities to see some of the intricate models that are made to-day for study and experiment in the world of industry, engineering and invention, because if they are shown in public at all it is usually at specialised exhibitions. So I think you may be interested in reading about some of these unusual models and seeing pictures of them.

A unique example is a sectional model made some months ago for The Superheater Co. Ltd. of Manchester, by Bassett-Lowke Ltd., at Northampton. The purpose of the model is to show the design and method of working of the company's superheating system for steam locomotives, although the model itself does not work.

The model represents a longitudinal half section of a locomotive boiler, to a scale of  $2\frac{1}{2}$  in. to 1 ft. ( $\frac{1}{4}$  full size) and 6 ft. in overall length. As a rule such a model would be made all in metal, but in this case a new method was employed. The fire tubes and superheater elements were made from gunmetal, but the boiler shell and fire-box were made from multi-plywood and the superheater header was carved in hard wood. Hard wood lends itself to a much better finish than metal, in addition to which the large proportion of wood makes the model lighter and easier to handle and transport.

As the purpose of this model is to demonstrate the principles of superheating, as well as the special design of the MeLeSco superheater, it is finished in various colours, in the manner of a descriptive diagram. Against the steel grey of the boiler fire tubes, the line of saturated steam from the boiler dome through the header and first element tube is shown in blue; it changes to red as the steam passes through the final elements to the superheated chamber of the header and on to the cylinders.

With the smooth, clean finish made possible by the use of wood wherever suitable, this sectional model fulfils its purpose very well and justifies itself as an experiment in modelmaking. Doubtless it will be the forerunner of many models of a similar kind built in this way.

Now a few words about a working model, this time built only partly in section; a civil engineering model that incorporates a certain amount of

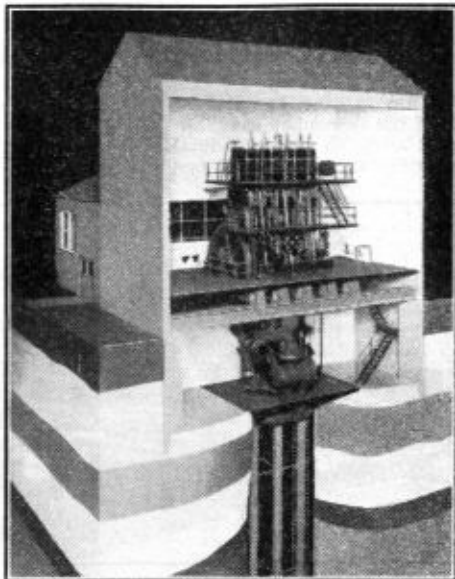

Working model of a modern pumping station, made to the order of Kingston-upon-Hull Corporation.

architectural modelling as well. This is a working model of a modern pumping station, made to the order of the Kingston-upon-Hull Corporation for reference and display purposes. The complete model is 3 ft. 6 in. high and 2 ft. 6 in. square, being to a scale of  $\frac{1}{4}$  in. to 1 ft.

The sectional part of this model shows the strata of the earth through which the boring is made for the well, with the three rising mains shown complete. Above ground level the power station is modelled, complete with boiler house, but with one wall entirely removed to reveal the entire pumping plant, with Worthington-Simpson triple expansion steam engine. The adjacent boiler house has glazed windows to allow a good view of the interior with the Lancashire-type boiler, complete with all external fittings and details. The exterior of the power house is most realistic, having embossed miniature bricks with clear white pointing. The model is electrically operated to indicate movement of the various parts of the plant.

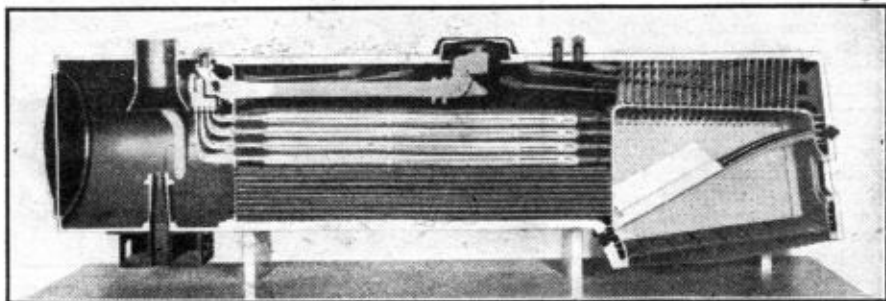

Exhibition model of a locomotive boiler, smoke-box and fire-box, made to the order of The Superheater Co. Ltd.



# Making Escalator Handrails Fit

## A Novel Machine Used by London Transport

By T. R. Robinson

THE escalators or moving stairways installed in most of the London Underground Railway stations sometimes present unusual problems for the London Transport engineers. The moving handrails, which keep pace with the stairway, are an interesting instance of just such a problem. They are made in the form of thick, flexible belts, built up of several layers or "piles" of cotton duck moulded into rubber, which is vulcanised in much the same way as a cycle or motor tyre. When in position on the escalators, the handrails are driven by cast-iron wheels that engage with their undersides, and the correct tension for maintaining the drive and keeping the handrails in place on the escalators is applied by simple stretching mechanisms.

New lengths of rail stretch considerably when first fitted. The increase is as much as three to four per cent. of the total length, and this is more than the tensioning gears of the escalators can deal with. Some means of pre-stretching the rails before fitting has to be adopted therefore in order to avoid the need for several adjustments whenever new handrails are fitted to escalators.

Until recently this initial stretching process was done by the application of tension while the rails were lying in wooden troughs. As this way of doing it was slow and not entirely satisfactory, the engineers decided to construct a special machine for the purpose, which would be capable of handling several lengths of rail simultaneously. The machine they designed can deal with four 120-ft. lengths of handrail at once, and these rails are not only stretched, but are also thoroughly flexed and "run in" at the same time.

At the driving end a powerful electric motor, operating through enclosed worm reduction gear, rotates a spindle carrying four large wheels, or "sheaves," round which the lengths of handrail are passed. The baseplate on which the sheave spindle bearings are mounted is made of concrete.

From the driving end the handrails

pass along guide rails mounted on a light girder frame structure, and then round further sheaves at the tension end of the machine. Each tensioning sheave is fitted to its own individual short spindle, and the bearings of each spindle are mounted on a small frame, or carriage, fitted with four flanged wheels. These wheels run on light rails attached to the top of the main frame supporting the sheaves, and so each carriage and its sheave can move a certain distance in a horizontal direction. A steel wire rope is attached to each carriage and, after passing over a pulley on the main frame, is linked to a heavy

weight. The pull of the weight, acting through the wire rope, tends to draw the carriage and its sheave along the rails and towards the end of the machine, and so applies the necessary tension to the handrail.

As the weights are made in sections, any desired load can be applied to any particular handrail undergoing treatment in the machine, and the amount of stretch can be measured by noticing the distance travelled by the sheave carriage concerned.

The general design of the machine is as similar as possible to the actual escalator mechanism, so that the rails undergo the same kind of strain as that met with in normal service.

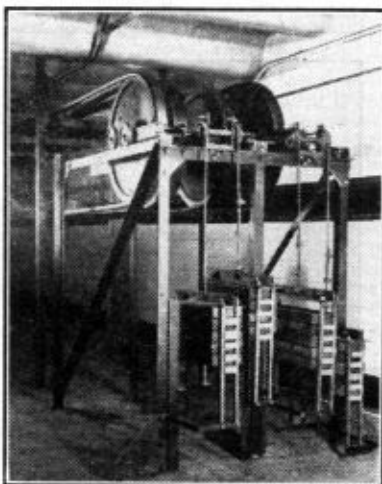

The moving end of the stretching mechanism on which escalator rails for London's Underground are run in. Photograph by courtesy of London Transport.

# Sugar from Beet

By W. H. Owens

LAST autumn for three or four months huge modern factories, mostly in the eastern counties of England, worked day and night, seven days a week, converting endless loads of dirty-white beet into pure granulated sugar. Our future supplies of sweets and chocolate largely depend on the season's work in these factories.

Although the beet sugar industry was established in this island less than 30 years ago, it is now among the most important sources of home-produced food. About 500,000 tons of high grade domestic sugar, which represents a weekly ration of 8 oz. for everybody in the country, is produced each year from beet grown on British farms. This is a very useful contribution towards the nation's sugar requirements and, moreover, means a saving of millions of dollars on sugar imports from abroad.

In 1921 there was only one sugar factory operating in Great Britain. To-day there are 18 in England and one in Scotland, and they deal with a crop of some 400,000 acres grown by farmers in many parts of the country. A large part of the crop is raised in the Fen District, where the sugar beet plant thrives particularly well in the rich peaty soil of land that was anciently reclaimed from the North Sea.

Most factories handle an average of 2,000 tons of beet every 24 hours. All of them are the most up-to-date of their kind and have been designed for speedy and continuous output. The time factor is very important in beet conversion, because once the roots accumulate in the factory silos they must be processed quickly if deterioration through heating is to be avoided.

As thousands of farmers supply each factory during the season, the loaded lorries and railway wagons arrive in an almost endless convoy. This beet traffic must be very rigidly controlled to ensure steady uninterrupted supplies and at the

same time to avoid congestion. Thus the growers are given special permits which entitle them to deliver so many tons of beet on given dates. Without these permits no consignments can be accepted.

Transport is mainly by road or rail, and in parts of the Fens new roads have been laid down in recent years to facilitate the moving of heavy crops from farm to factory. Some farms are also directly linked with the factories by river or canal, and the flat-bottomed barges used on the slow-moving waterways of eastern England are ideal for transporting beet cargoes at

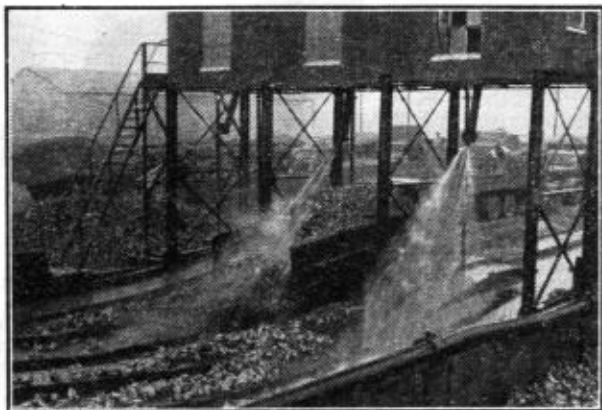

High pressure water guns washing beet from lorries bringing roots to the Peterborough sugar factory. The illustrations in this article are reproduced by courtesy of the British Sugar Corporation Ltd.

the lowest cost.

The first of many processes in the conversion of beet into sugar is the washing of the roots to free them from all clinging dirt and external impurities such as stones, leaves, straw and so on. From the loaded silos, which hold up to three days' supply, the beet are driven by water power along concrete flumes direct to the washing machines installed at a central point in the factory. Large wooden paddles stir up the beet in gallons of warm water and so remove all the soil from them.

At some of the bigger factories the roots are actually washed out of the lorries by high-pressure water guns and floated directly along the flumes to the washing machines. This method of direct unloading saves much time. But before every week-

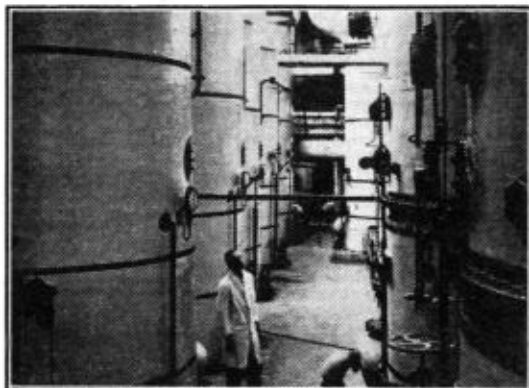

Evaporators in which thin juice made by boiling sliced beet in water is concentrated before passing to vacuum pans for crystallisation of the sugar.

end great stacks of beet must nevertheless accumulate in the factory yards and silos to provide the necessary supplies from Saturday until Monday, when the hauliers are off duty.

After washing, the beet are pitched out on to a travelling conveyor belt, known as the "picking table," where they are carefully inspected, and any remaining foreign matter, stones and badly-topped roots are removed by hand. Next they are hoisted on a huge wheel, or in some cases pumped to the slicing machines at the top of the factory. The slicers are large steel vats containing sets of knives which, as they revolve, shred up the beet into wafer-like slices known as cossettes.

From these cossettes the sugar juice is extracted. Automatic conveyors feed them wholesale into a series of diffusing tanks, like giant tea-pots, where the sweet juice is drawn off by a process similar to the brewing of tea. When the tanks have been packed with tons of cossettes, very hot water is passed through them. There may be 10 or 12 tanks, all connected up by piping. The diffusion from the first is run into the

second, that from the second to the third, and so on down to the last. In this way the resulting syrup, or "Thin Juice," is made as concentrated as it can possibly be.

All the remaining beet pulp is compressed, dried and bagged, and is returned to the farms as a useful feeding-stuff for cattle. Nothing at all is wasted in the sugar factories.

The thin sugar juice still contains a certain amount of impurities, and to remove them the juice is passed through tanks containing milk of lime. To supply this each factory has its own lime-kilns, burning approximately 60 tons of limestone and six tons of coke each 24 hours. Then carbon dioxide gas, generated in the kilns,

is bubbled through the mixture to separate the lime and all the impurities with it. The juice is next filtered under pressure.

By this time the juice has become a clear liquid only a little thicker than water. It is now pumped into huge evaporators, great steel towers connected with a maze of pipes and occupying both sides of a whole floor in the factory. In these evaporators the thin juice is boiled into a thick, treacly liquid from which the raw sugar crystals will be obtained.

After a further purification with sulphur, the sugar is crystallised out in vacuum boilers. The operators of these boilers are the most skilled men in the factory; they know, by long experience, just how to produce sugar of any desired "grain" or size of crystals. That part of the sugar which does not crystallise is called molasses and is separated from the sugar crystals in centrifugal machines. These machines contain high-speed drums with perforated sides; and as the drums whirl around, the powerful centrifugal force drains the liquid molasses away leaving the solid crystals behind. This last

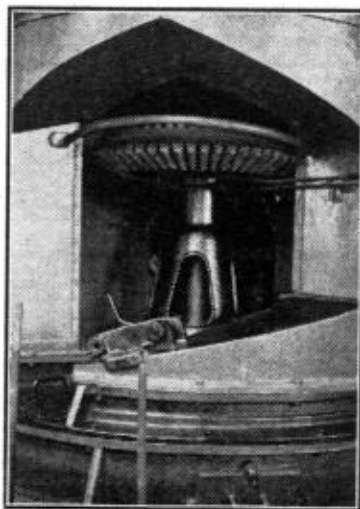

One of the mills for slicing beet in the sugar factory at Bury St. Edmunds, the largest in the world.

(Continued on page 94)

# BOOKS TO READ

Here we review books of interest and of use to readers of the "M.M." With certain exceptions, which will be indicated, these should be ordered through a bookseller.

## "COLOURS AND HOW WE SEE THEM"

By H. HARTRIDGE, F.R.S. (Bell. 15/- net)

Some of the finest books on popular science ever written have been the result of invitations to famous scientists to give the well-known Christmas Lectures of the Royal Institution, London. The first book of this kind that has been produced since the war is a record of lectures on colour by Professor Hartridge, whose subject is one of great fascination and much beauty.

We are apt to take colour for granted, and our enjoyment of it will be increased when we learn from this book just how colours are produced, and how they are used by Nature and by man. The separation of the colours of white light by the spectroscope is fully dealt with, and we learn many interesting details of the strange rays outside the visible spectrum, including the heat rays of greater wavelength than ordinary light and the fascinating ultra-violet rays, X-rays, and gamma-rays given off by radioactive materials.

Among the many secrets of Nature here unveiled and explained are the colours of the sky, the sea and the Aurora, and those of plants, birds and butterflies. The effect of lighting on colour is traced and the mysteries of phosphorescence and fluorescence are dealt with. How colour is recorded is explained, and we learn also how the eye works in distinguishing one colour from another. The colour processes of photography, printing and television are described, and there are some splendid experiments on illusions in which colours play a part and on the remarkable effects that can be achieved with polarised light. Finally there is a section on colours with strange properties, and the use that can be made of them in effective scientific magic.

The illustrations, many of them in colour, are an attractive feature of the book.

## "RAILWAY SIGNALLING"

By MAXWELL TAYLOR (Sampson Low. 3/6)

The remarkable safety record of British railways over the years owes a great deal to the thoroughness and reliability of signalling. This is one of the aspects of railway work on which the ideas of the average traveller are somewhat hazy. The book under notice sets out to remedy this state of affairs and in general it can be said that it succeeds very well in explaining how signals work and what they mean.

The origin and development of signals are first described, and then the principles of the block system and single-line working are dealt with. Fog working and automatic train control also receive due treatment, and we end with an account of modern equipment and apparatus, and a discussion of possible future developments.

The book is well illustrated with photographs and drawings.

## "THE LYNTON AND BARNSTAPLE RAILWAY"

By L. T. CATCHPOLE (Oakwood Press. 6/-)

The remarkable popularity and interest of light or narrow gauge railways is shown by the appearance of the fourth edition of this account of the Lynton and Barnstaple Railway, the first of which was published in 1936. The book was originally produced as a memorial volume to the attractive little 2 ft. gauge system described.

The story is well told, from the earliest years to the final disposal. Construction, engineering features, the route itself and the equipment that operated the traffic are all dealt with, and there are good maps, diagrams and illustrations.

## "AEROMODELLER ANNUAL 1949"

(Model Aeronautical Press Ltd. 7/6)

The first "Aeromodeller Annual" appeared last year, and proved so popular that it has been decided to make it an annual publication. The contents of this, the second edition, are completely new, and the 30 or so model aircraft described and illustrated in it reflect the best of the world's models in 1949. The descriptions are supplemented by excellent half-tone photographs and pages of neat scale drawings. Another selection of new and useful aerofoil sections is included, together with summaries of past "Aeromodeller" engine analysis articles, helpful "gen." on radio control adaptations, and up-to-the minute tips on solid aircraft construction.

Model aircraft enthusiasts who are thinking of entering their models in any of the national contests will find in the Annual a very useful list of the names and addresses of national model aircraft governing bodies, and there are full details, with many illustrations, of the results of the Wakefield Trophy and S.M.A.E. Contests last year. This book is invaluable to every serious aeromodeller.

## "FOSSILS" and "FRESH WATER"

By I. O. EVANS (Warne. 10d. each)

Mr. Evans has now produced two further booklets in the "Nature's Treasure" series. The first deals with simple fossils, explaining what they are and suggesting where they can be found. The second reveals many surprising and interesting features of that most familiar of all natural substances, water. From it the reader will learn something of the hardness of water, and will discover why a needle can be made to float on the liquid. Ripples and waves, rivers and canals, dams and water power also are explained, and how water is collected and brought to our household taps is well described.

Both books are simply written for the benefit of young readers, and in each case there are good drawings to illustrate the text.

## "THE ROTHER VALLEY, LATER THE KENT AND EAST SUSSEX RAILWAY"

By M. LAWSON FINCH. (7/6)

The Kent and East Sussex Railway, now part of British Railways, was one of the several light railways of standard gauge with which the late Lt. Col. H. F. Stephens was associated. The author has put together the fascinating story of this Kentish system, which began operations as the Rother Valley Railway between Robertsbridge and Tenterden. Its varying fortunes and the quaint character of much of its equipment are well described, and there are many photographic reproductions of considerable interest.

Maps and station layout plans help the reader to follow the story and railway ticket enthusiasts will be pleased with the reproductions of original Rother Valley and later Kent and East Sussex tickets.

The book is published by the author at Castleton, Dunton Green, Sevenoaks, Kent.

## "A GREEN FOX"

By KATHLEEN MACKENZIE (Evan Bros. 6/- net)

Those who like books about the real country, riding and hunting will enjoy this story of the four Pentire girls. They live on a farm in Cornwall, where they look after their own ponies, and meet with unexpected adventures when hunting and attending Pony Club meetings. Life for them is made difficult by a rascal who sets fire to stables, steals hounds and poisons foxes, crimes of which the Pentires are themselves suspected, but by splendid detective work the girls trace the culprit and expose him.

**"BRITISH RAILWAYS FOR BOYS"**

By CECIL J. ALLEN, M.Inst.T.  
(English Universities Press Ltd. 5/-)

This latest work of perhaps the best-known railway writer of to-day is described as a "Junior Teach Yourself Book." It is designed to help the boy who begins merely watching trains, or taking locomotive names and numbers, to a much wider understanding of railways as a whole. In this it should be successful.

British Railways as a national concern and their independent predecessors are first dealt with. Then the various factors that affect the choice of route in building a railway are considered, and bridges and other engineering or lineside equipment are discussed. Locomotives, their working and the trains they haul form the subject of later chapters, while coaching stock from compact "tube" trains to spacious Pullmans, restaurant, buffet and sleeping cars receive their share of attention.

Accounts of freight handling, train movement and control round off the description of things as they are now, and the final chapter weighs up the chances of the various forms of motive power of the future.

The illustrations are well chosen and reproduced. Most of them are half-tones, but there are some interesting line drawings.

**"THE SECOND METEOR BOOK FOR BOYS"**

Edited by JOHN BLAIR (Chambers. 6/- net)

In its 156 pages the second "Meteor Book" contains eight stories and twelve articles. The stories are varied in character and all are exciting. The articles provide more serious reading, and this is of a very attractive character. These contributions are written by experts. They include stories of buried treasure and superstitions of the sea, with an account of that famous mystery, the "Marie Celeste" case. Then we have tales of smuggling on the Thames, modern treasure hunters, rockets and the conquest of space. Other articles that will appeal to modern boys deal with gliding and with the early days of cricket, and there are also drawings of pike and other British game fish.

The book is well illustrated by excellent line drawings.

**"THE A.B.C. OF BRITISH RAILWAYS LOCOMOTIVES"**

(No. 2. Nos. 10000-39999)  
(Ian Allan Ltd. 2/-)

This revised and improved booklet is compiled in the usual "A.B.C." style. It deals first with the diesel and electric locomotives of all Regions of British Railways, and then with the steam locomotives of the Southern Region. As usual in A.B.C. locomotive booklets, principal dimensions, numbers and names of the various classes are dealt with in order in the S.R. section, and the traffic classification adopted by British Railways is explained as it affects Southern engines.

Illustrations are ample in number and many of these show engines in various B.R. styles of finish.

**"CYCLING TOURING GUIDES"**

No. 5. The Midlands

By HAROLD BRIERCLIFFE (Temple Press, 2/6)

Here is another valuable guide to cyclists. The present volume deals with the Midland Counties, the only section of those covered in this series that lacks a coast. The district has compensating attractions, including the Severn, the Mersey and the Dee and their estuaries, and the mountains of the Peak District, and the routes and tours here described will be of interest to visitors from other parts of the country as well as to those living in the area itself.

Beginning with the Peak District, each chapter deals with a special section, describing the approaches and giving interesting details, not only about roads and natural features, but also about towns and villages. Useful information on distances are given, and the illustrations include reproductions of photographs as well as line drawings.

**"CAMBRIAN JOURNEY"**

Edited by REG TAYLOR. (3/-)

The Welsh Advisory Board of the Youth Hostels Association have had the happy idea of producing an illustrated guide to hostelling in Wales. The booklet does not aim to be a complete guide to that attractive country, nor does it mention every hotel that has been established there. What it does is to outline a journey from south to north through magnificent moor and mountain country, and to read this outline is to be impelled with a desire to make the journey. The wish to do this is strengthened on looking at the magnificent photographs by Mr. W. A. Poucher and others that are reproduced in the booklet and by poring over the pictorial maps and other decorations that have been contributed by Mr. J. R. S. Craigie. Mr. Edmund Vale, who contributes the Foreword, found reading the booklet a joyful and refreshing experience, and all who are attracted by mountains, moors and valleys will agree with him.

The mind of the reader, or of the traveller who sets out to make the actual journey, is prepared by a delightful account of hill farming by Esme Firkank that will enable him to appreciate the character of the country over which he has to pass and its inhabitants. The journey begins at Chepstow, in the Wye Valley, and is divided into three sections. The first of these takes the traveller over the Brecon mountains to "Little England beyond Wales" and then up through the wildest country to Llandrindod. Plynlimon and the upper waters of the Severn are the central features of the next stage, which ends at Dolgelly, and from there the reader is taken northward into the massive mountain region centred on Snowdon, the journey ending at Llangollen after the passage of the Berwyns. It is surprising how much information is packed into so little room, and anyone who explores the wonderland of Wales with the booklet as a guide will learn to know the country thoroughly, whether he makes the journey in one swoop or covers its length in sections.

The booklet can be purchased through booksellers, and it can be obtained direct, price 3/- post free, from the Youth Hostel Association (England and Wales), Welwyn Garden City, Herts., or from any regional Y.H.A. office.

**"LITTLE MISS PINK AT THE GREAT HOUSE"**

"LITTLE MISS PINK'S SCHOOL"

By RODNEY BENNETT (Harrap. 3/6 each)

Little Miss Pink, that delightful creation of Rodney Bennett, is an old friend. In a previous book we left her installed in a Great House, and now we have the story of her life there, along with the family of mice who befriended her and found a home for her. In the Great House she opens a school, which proves a wonderful success, and as a climax to the story we have a School Parents' Day, attended by the Mayor of Mousington, a gorgeous figure in a red robe and cocked hat, followed by wonderful Christmas festivities. Admirers of Miss Pink and new friends of hers among our youngest readers will thoroughly enjoy this further story of her career, which is beautifully illustrated by Astrid Walford's pictures in colour.

**"THE OBSERVER'S BOOK OF AIRCRAFT"**

By JOSEPH LAWRENCE (Warne. 4/6 net)

This edition of a work first published in 1942, when the world was at war, has been so extensively revised as to be almost a new book. Like the original edition, it has been compiled with the object of facilitating quick recognition of aircraft, and the 109 machines dealt with include both piston-engined and jet types, helicopters and gliders.

Brief descriptive notes on each machine are accompanied by a good half-tone photograph and, in many cases, a 3-view silhouette. There is a useful glossary of aircraft technical terms, and a pictorial supplement illustrating recent British military and civil experimental types of aircraft. The book is of convenient size for slipping into the pocket.

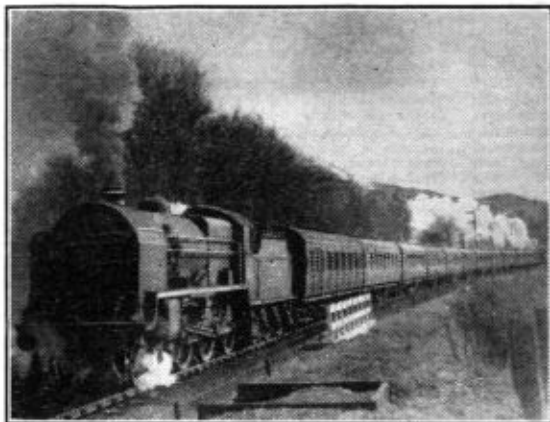

L.M.R. No. 45541 "Duke of Sutherland," with bank engine assistance, climbs away from Oxenholme with a Perth express. Photograph by J. D. Mills, Birmingham.

## Railway Notes

By R. A. H. Weight

### Locomotive Developments Overseas

Among interesting innovations or developments lately reported has been the placing of an order by the Norfolk and Western Railway, U.S.A., for a new type of coal-burning steam-turbine, electrically driven 4-8-4-8 locomotive of great size for freight service. An exceptionally high boiler pressure of 600 lb. per sq. in. is contemplated, the boiler being of the water-tube type. It is hoped in conjunction with steam-turbine electric drive to secure a very high rate of thermal efficiency, though building as well as maintenance costs may be high. There will be 12 traction motors, one mounted on each axle of the locomotive. With a very large tender the engine will weigh over 400 tons.

More diesel-electric locomotives are under construction or have already been completed by the English Electric Company for the Egyptian State Railways. These include twelve of 1,600 h.p. for main line passenger service. Between Cairo and Port Said this involves the traversal of desert area with the track running for some distance parallel with the Suez Canal, for many years the haunt of European-built 4-4-2 steam engines. Diesel-electric set trains for express and suburban work with power units at each end have also been ordered. The 1,600 h.p. express locomotive is similar in many respects to the first L.M.R. main line engine of this type, No. 10000, and its sister unit.

Construction has been continuing at the works of the North British Locomotive Co. Ltd., Glasgow, of the "24" class 2-8-4 freight class for the South African Railways, 100 having been ordered of this new type. They have outside cylinders, 4 ft. 3 in. driving wheels, and are designed to be within weight limits for comparatively light rails of 3 ft. 6 in. gauge. A novel feature is the cast-steel bed in which the cylinders and hind covers are cast integrally with the frame sides and stretchers.

Forty 2,500 h.p. electric locomotives are on order for the South African Railways, which at present possess some 2,600 steam engines of many classes

having the high average tractive effort of 33,429 lb. Beyer-Garratt articulated engines of great power, with big fire-boxes and mechanical stokers, continue to play a notable part in traffic working over heavy grades.

With locally-built or other locomotives, often more powerful nowadays and standardised to a greater degree than hitherto, the railways of the European countries that were considerably devastated during the recent war are going ahead with improvements to services and rolling stock; and the possibilities of diesel or electric traction are not being overlooked.

### Electric Traction on South African Railways

From notes received from a Pretoria reader, we learn that the overhead system of current collection is in use on three electrified suburban lines radiating from Cape Town, on numerous routes around Johannesburg, and on the long Natal main line from Durban into the Transvaal and in the Orange Free State. Plans are in hand for completion of a 500-mile stretch, including long gradients, from Durban to Johannesburg, we are informed. It is for such long runs that the large electric locomotives reported above are necessary.

Further electrification extensions in hand include a 100-mile length north of Cape Town on the main line through the tortuous Hex River Pass with its sharp curves and 1 in 40 gradients. Some of the severity of this route will be eased when a new long tunnel and a number of shorter bores have been completed. Multiple-unit trains consisting of from four to eight coaches operate suburban services.

### New Luxury Trains in Australia

The "Riverina Express" recently placed in service between Sydney (New South Wales) and Albury, on the border of Victoria, carries first and second class passengers in movable reclining seats which form part of the equipment of the red-brown air-conditioned coaches. The formation includes a buffet-dining car. This fine train, like the "C-38" green 4-6-2 locomotives, was built in Australia and is similar to the "Newcastle Express" introduced in 1948 between the State Capital and Newcastle, N.S.W. A diesel generating unit carried on the "Riverina" provides current for lighting, air-conditioning, public address system, hot water and cooking. Other luxury trains are to be introduced soon to provide fast daylight services.

### Historic Locomotives and Relics

As a result of discussions between the Railway Executive and representatives of the principal Societies interested in the preservation of historic locomotives a joint committee has been formed to consider the extent to which suitable models, historic nameplates, or other important relics indicative of various phases of locomotive development during the last 100 years or more could be collected together for exhibition and preservation. Some actual historic locomotives belonging to famous classes which have long been withdrawn from active service are, of course, preserved, particularly in the Railway Museum at York; but it is felt that similar retention on a larger scale would present considerable problems in the way of accommodation and maintenance.

### New Standard Cab Design Inspected

Full general details have not yet been disclosed of the first of the new British Railways standard steam locomotive types intended for building in 1951. In order to obtain comments and opinions from Locomotive Inspectors and Drivers before the design

is proceeded with, a full-size "mock-up" has been constructed showing all relevant parts from the front of the fire-box as far back as the middle of the tender. This includes all controls and fittings in the cab as they would be seen and handled by the drivers and firemen of the future.

A "mock-up"—well known in aircraft work—is a full-size or scale model constructed in light material so that it is easily portable and taken to pieces but it is at the same time true to life and correct in its representation of design or detail. Such have been made and displayed to practical men on some occasions before but, on the other hand, one has often heard uncomplimentary comments on cab or other locomotive fittings which seem to have been placed with little regard to the convenience of footplate crews.

The opportunity now exists to perfect, if necessary, what are considered to be the best practices from each of the railway regions, in addition to several new ideas incorporated in the new design for which final drawings soon will be made. Care has already been taken to present the simplest possible layout of fittings easily accessible to the driver or fireman, to provide a firm, level floor right back to the tender; lockers for food, tools and clothing, good window arrangement and lookout, with ventilation. The photographs reproduced on this page give a good idea of the "mock-up" recently exhibited at Railway Executive Headquarters.

#### News from the East Coast Route

The five "A1" 4-6-2s built at Doncaster with roller bearings on all axles are allocated as follows: No. 60153, York; Nos. 60154-5, Gateshead; Nos. 60156-7, King's Cross. Continuing construction there of ordinary bearing "A1s", Nos. 60158-60 had been completed at the time of writing; the first named is stationed at King's Cross, the next two at Haymarket, Edinburgh. North Eastern type "J72" 0-6-0 shunting tanks completed at Darlington were numbered 69001-11 and allocated to sheds in the N.E. Region, more being in hand.

Several of the "A2/2" rebuilt "Cock o' the North" 4-6-2s have been transferred from Scotland, where they had always normally worked; to the N.E. area and are to be seen at York, while No. 60506, "Wolf of Badenoch" of this class, has been transferred further south to Peterborough. Several more Peppercorn

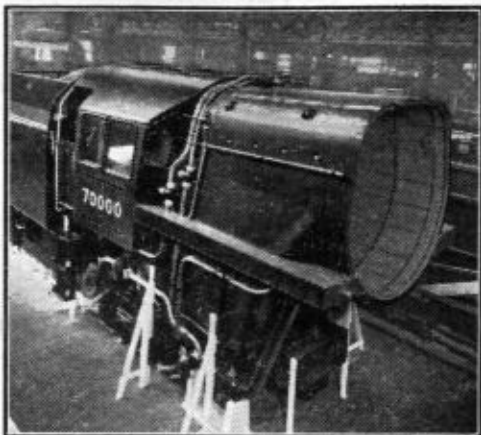

A general exterior view of a "mock-up" representing proposed standard cab and footplate arrangements for future British Railways locomotives. (British Railways official photographs).

"A2s" have moved to the Scottish Region. Some of these engines are being fitted with "Kylchap" double chimneys, also multiple-valve smoke-box regulators. Although they have worked on the West Highland line and elsewhere, the new "K1" 2-cylinder 2-4-0s are in the main allocated in batches of ten to English sheds: Darlington, Gorton, Blaydon, March. The last news of fresh ones coming into traffic from the North British Locomotive Company's Works include Nos. 62051-5 to be stationed at March, this being the second batch there.

There are now many more large-wheeled "Pacifics" painted blue; dark green-finished engines, or lined black as applicable, in either case with B.R. emblem, being also prominent. "C1" 4-4-2, No. 2877, has been withdrawn, No. 62885 having taken her place at Sheffield from whence these fine old G.N. "Atlantics" work to Cleethorpes and elsewhere. The arrival of a "Claud Hamilton" 4-4-0, No. 82535, to work on the west side of England on the Cheshire Lines last autumn was said to be the forerunner of a batch to be transferred from Great Eastern metals.

Just before Christmas the "Tees-Tyne Pullman," the fastest long-distance train on the East Coast route, was being worked to and from Newcastle by the streamlined King's Cross "Pacifics" "Mallard" and "Sagull," following a spell of regular running on alternate days by the roller-bearing new 4-6-2s Nos. 60156-7, Nos. 60154-5 at the same time were often on the "Night Scotsman," up or down, between Newcastle and London with no looked stop in a 268-mile run.

#### Western Tidings

New engines completed at Swindon in November last were: 2-6-2T, Nos. 4174-8; light 0-6-0T, Nos. 1605-12; and diesel-electric shunter for Bristol No. 15107.

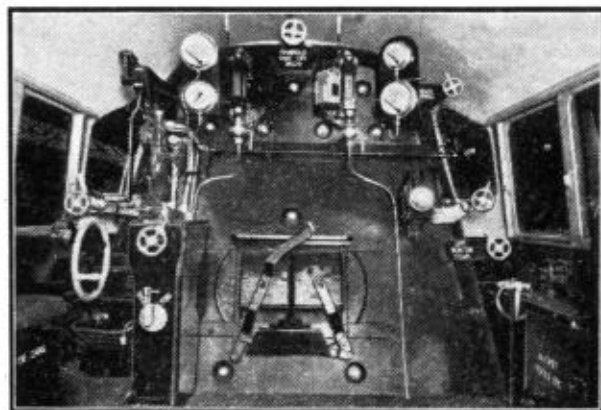

The proposed arrangement of footplate fittings on the "mock-up" recently prepared. The layout aims at simplicity and convenience in handling.

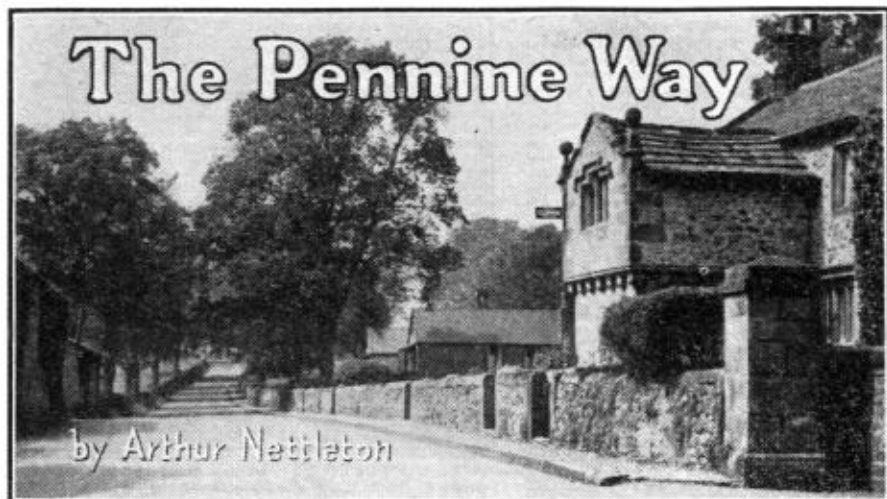

THE Pennine Range, England's backbone, is a grand area for hiking in either summer or winter. Along its 250 miles, or within a short distance on either side, lie many places of beauty and interest. Windswept fells, rolling moors, wooded dales, pleasant villages, and many historic relics are to be found there.

The region is already well-known to many outdoor folk. Soon it may have a still greater appeal and become even more popular among walkers, for parts of the district have been earmarked as potential National Parks, and a further idea is to establish a "Pennine Way" as a walkers' route from Derbyshire to the Cheviots. This latter project, indeed, has been in the minds of certain open-air enthusiasts for some years, but the National Parks scheme has directed attention more strongly to the proposed "Way." This would, in fact, link up three of these national playgrounds — the National Parks of the Peak District, the Yorkshire Dales, and the Roman Wall.

The long footpath route was first suggested in 1935, and in 1938 a Pennine Way Association was formed in conjunction with various bodies interested in rambling and camping. The enterprise received the support of the Youth Hostels Association, societies for the preservation of footpaths and other organizations.

What exactly is this "Way," and where will it run? You mustn't imagine it as a broad macadamized pavement winding

its way along the Pennine Range. It is intended to be simply a trodden footpath, with rustic bridges and signposts that do not jar with the beauty of the countryside. Neither will it take the shortest route from Derbyshire to Northumberland. But it will be 250 miles long, and already much of it actually exists in the form of paths and tracks known to hardy walkers.

Why, then, is there a Pennine Way scheme at all? The project is necessary because public access does not exist along the whole of the route. Certain stretches are closed to walkers, particularly at the southern end of the Way, in the Derbyshire Peak District. The purpose of the scheme is to make the route continuous, so that walkers may tramp along England's backbone right from Edale to Wooler.

Ultimately, it is pointed out, Youth Hostels at various points will enable the walker to traverse the Pennine Way in stages. Such hostels have existed in the region for a number of years, and the list is being continually increased.

In addition to walking along the Pennines, outdoor folk will have better opportunities to explore some offshoot routes, which go to places of beauty and interest. From Edale, the Way will cross Kinder Scout, the plateau that is a popular retreat for energetic Sheffield walkers. It will pass the Snake Inn, the hostelry which gets its name from the snake in the emblem of the Cavendish family, and the route

A peaceful hamlet near the proposed Pennine Way is seen at the head of this page. It is Eshton, between Skipton and Malham.



will then go to the beautiful Derwent Valley, with its man-made lakes, and forward by way of Greenfield and Blackstone Edge to the Calder Valley near Todmorden.

Blackstone Edge has a unique treasure, in the form of what is claimed to be the longest stretch of old Roman road yet recovered in Britain. It was revealed last century by some Manchester antiquaries, and about a mile of it is now visible. A curious feature is a central channel in the paving. The purpose of this channel is not now definitely known, but it has been said that a tree trunk was dragged behind Roman vehicles as they descended the incline, to check their speed, and that the groove was worn in this way. Recently doubt has been cast on the Roman origin of the road, which may be just a packhorse route.

Wycollar Dean, near Colne, is close to the next section of the Way. It is a lovely retreat, unspoiled by industry, and there is a fine old packhorse bridge spanning the stream. Nearby are the ruins of Wycollar Hall, a mansion which appears

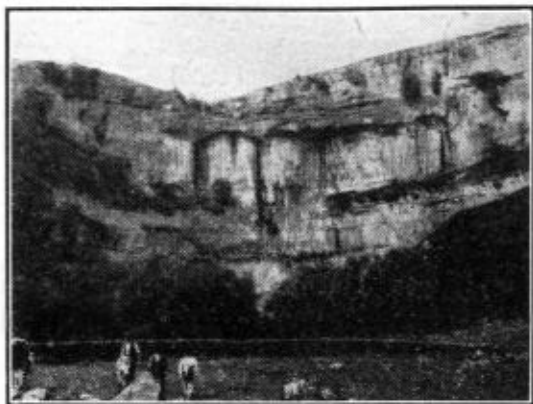

The great natural amphitheatre of Malham Cove, from the foot of which the River Aire starts its journey towards the sea.

in Charlotte Brontë's "*Jane Eyre*."

The heart of the Brontë country, at Haworth, can in fact be reached easily from this part of the Pennine Way. The main route runs northwards towards a gap in the Aire Valley near Skipton, crosses to Malham, and thus reaches the limestone fell country, where lie such geological wonders as Malham Cove and Kilnsey Crag.

Malham Cove holds a mystery, for the River Aire originates in the tarn above this cliff and descends by an uncharted route behind the cliff face before emerging at the foot. The cove is 286 ft. high, more than two-thirds as high as St. Paul's Cathedral, London, and nearly a quarter of a mile wide. The huge bole of Kilnsey Crag, overlooking Higher Wharfedale, was actually formed by the action of the sea, in the far-distant times when England was inundated.

The next stages in the Pennine Way will take the walker by Fountains Fell and Penyghent (2,273 ft.) to Horton-in-Ribblesdale and along an old packhorse trail to Hawes. Thence from Wensleydale over to Swaledale and onward to Keld and Tan Hill.

Keld is one of England's most isolated villages, surrounded by wild fells and rugged cliffs, though the place itself lies snugly in a deep hollow of the Pennines. Tan Hill Inn, 1,732 ft. above sea level, is one of the highest in the country.

From Keld the Pennine Way is planned to reach Teesdale by way of what is called the Stainmoor Gap. After following this dale westwards to the hamlet of Dufton, the walker will strike northwards

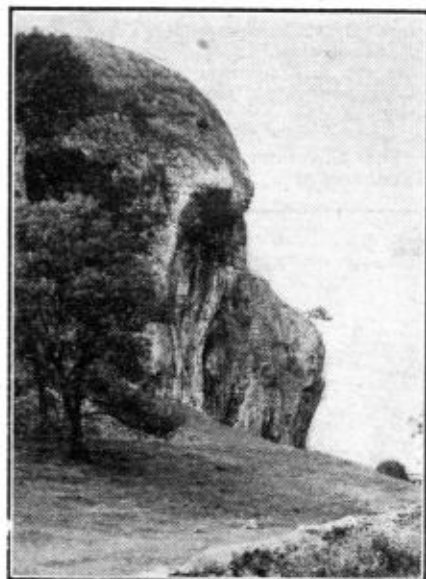

Kilnsey Crag, a limestone rock in which are fossil remains of sea creatures of the distant past.

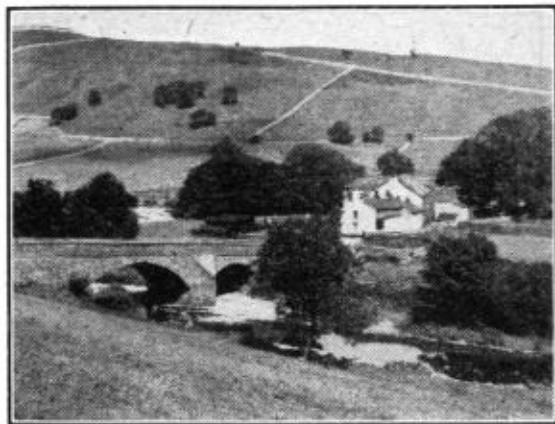

Kettlewell, in Upper Wharfedale, a typical village of the Yorkshire Pennines region.

for the Roman Wall, beyond which is the route to the Cheviots and the end of the Pennine Way at Wooler.

The scenery along this 250 mile route is diverse, and nearby are old castles and historic village churches. Skipton Castle, near the Airedale section of the way, is a fine medieval fortress still in a good state of preservation. It was long the home of the Cliffords, who owned big tracts of land in North West Yorkshire and elsewhere.

One famous Clifford was the "Shepherd Lord" who spent his boyhood and youth in a shepherd's home, so that his father's enemies could not find him. Even after he succeeded to his properties at Skipton and elsewhere, he preferred to spend most of his time at the hunting lodge, Barden Tower, in Wharfedale.

To traverse the Pennine Way from end to end at an easy walking pace would take about 10 days, without allowing for detours in search of beauty spots and historic treasures off the main route. But the Way can be joined at any point, and there are several good centres that might be used as jumping-off places. Skipton is one of them; Settle is another; and Hawes is a third.

Youth Hostels already available include those at Barnard Castle, Malham, Bellingham and Keld. Each of these is on the route of the Pennine Way or close to it. In addition to serving the walker who wishes to follow the Pennine Way, the Barnard Castle Youth Hostel is a convenient centre

for scores of other footpath walks, while Barnard Castle itself is an old market town well worth exploring. It has connections with Dickens and Scott, too.

Keld Youth Hostel is 15 miles away, and from this place Hawes can be reached in nine miles. It is the gateway to the Buttertubs Pass, and one of the highest market towns in England. Askrigg, two miles from Hawes, has another Youth Hostel and is a place full of character. Castle Bolton, further along Wensleydale, was for a time the prison of Mary, Queen of Scots. During her imprisonment there she planned to escape, but her notes to her supporters were disclosed to her gaolers, and the plot failed.

How to mark the route of the Pennine Way, when it is completely established, is a matter about which there has been some controversy. Should it be indicated by splashes of paint on trees, fences and rocks, an idea adopted to show rights-of-way in some Continental countries? The Pennine Way Association suggest that on high ground a better method would be to erect cairns; at other points, a special type of signpost, effective but in harmony with the surroundings, might be adopted. Rustic footbridges may also be built across some of the streams that have to be crossed.

The Government have endorsed the Pennine Way

(Continued on page 94)

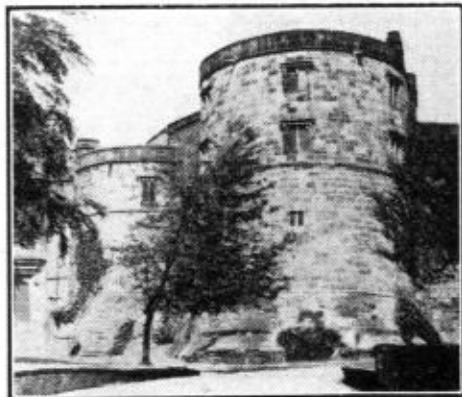

Skipton Castle.

# Photography

## Camera Work in February

By John J. Curtis, A.R.P.S.

**S**TREET photography is the subject selected for consideration this month; it is one that has never been overdone; possibly because it is so full of variety. There are shots to be made in busy thoroughfares or side streets, and not only when the sun is shining but also on wet days and even dull misty ones. Have you ever noticed what charming reflections can be seen on wet pavements, or the effect made when the sun is just breaking up the morning mist and its soft rays are making a real picture of that old half-

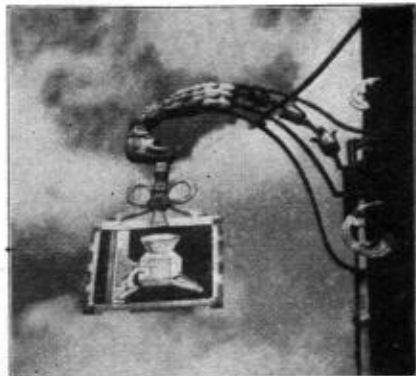

Old sign above wine merchant's shop in London. Photograph by A. G. Dell, London S.E.27.



Market Day. Photograph by N. V. Salt, Newcastle, Staffs.

timbered building?

A few minutes can be well spent in a doorway near the market place or shopping centre with the camera focussed on a stall of some kind where housewives gather, and the salesman, or woman, will soon be seen gesticulating and haggling about the quality and price of the wares. Then there is the old junk shop with its small windows and the keenly interested connoisseurs discussing the merits of some article that has caught their eye.

Keep a lookout also for any unusual shop signs, which are often to be found in quite unexpected places. A sign like the one in our top picture is well worth hunting for.

To achieve good results have a fast film, and if possible, make constant reference to your exposure meter because the light can vary considerably during a day in February, also some of the spots selected may be duller than others. Avoid making yourself conspicuous as you do not want the folks to notice what you are after. Estimate as carefully as possible the distance between you and them so that the focus is correct; have the shutter set at  $1/25$ th and the lens at F8, and bring the camera into position quickly when the persons have arranged themselves as you want. Remember that background and lighting are of very great importance; it is wisest therefore not to bother photographing subjects in which you have not a reasonable chance of getting these right.



The Antique Shop. Photograph by J. J. Curtis, A.R.P.S.

# The World's Biggest Refrigerator

By John W. R. Taylor

**A** PLACE where one can whistle up a snowstorm just by pushing a few buttons seems incredible; yet such a place does exist, at Eglin Field in Florida, one of the hottest regions in America. It is an enormous hangar, and was built for the U.S.A.F. so that its aircraft could be tested under all climatic conditions without being flown up to the Arctic Circle or to the Tropics. The hangar is

quickly their engines could be started from a frozen state. In the Tropics they were taxied on the ground for long periods with one half of their radiator covered up to see if their engines would over-heat. Ground equipment, tractors, tools and special clothing were also tried out under operational conditions.

The snag was that Nature did not always co-operate, and test parties sometimes had to sit around idle for weeks waiting for the right weather. Even then, if some item of equipment proved unsatisfactory and had to be redesigned, it could not be tested again until the next season, and nearly a year of precious time was wasted.

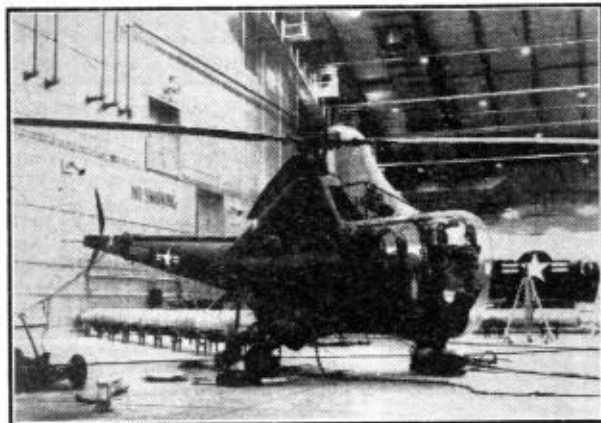

Sikorsky H5C helicopter undergoing climatic tests in the U.S.A.F.'s Climatic Hangar at Eglin Air Force Base, Florida. The illustrations to this article are reproduced by courtesy of the U.S. Air Force, Washington.

big enough to house more than 20 aircraft at a time, including a "Superfortress," and cost about £3,000,000 to build.

The vital need for thorough all-weather testing of military aircraft was made very apparent in the last war. When fighter planes were sent to Iceland, their lubrication oil congealed, rubber pipes became brittle, and plastic components broke in the intense cold. When the same types of aircraft operated in the Western Desert, their engines often over-heated and sandstorms clogged their mechanical parts.

As a result, special test stations were established by the R.A.F. and U.S.A.F. in places like the Yukon, Alaska and the Sudan, where aircraft could be flown and ground-run under extreme climatic conditions, to prove their suitability for action in any part of the world. In the Arctic, for instance, they were left in the open without covers, to find out how

of 57 deg. below zero, spot-lighting the need for properly designed clothing for groundcrews working in Arctic conditions.

The importance of climatic testing is thus well-known to Col. Ashley McKinley, a veteran North Pole explorer who commanded many U.S.A.F. test parties during the war. But even he was getting a little fed up with carting men and equipment to Alaska and Africa by the Spring of 1944. He decided that there was no reason why weather could not be made to order in a specially-built laboratory, and suggested to Gen. Grandison Gardner, who commanded the U.S.A.F.'s Air Proving Ground at Eglin Field, that Eglin would be a convenient spot for it. Quite apart from the fact that some of the U.S.A.F.'s best-equipped workshops and most highly-skilled personnel would be available to make speedy alterations to any parts which failed under test, it would permit

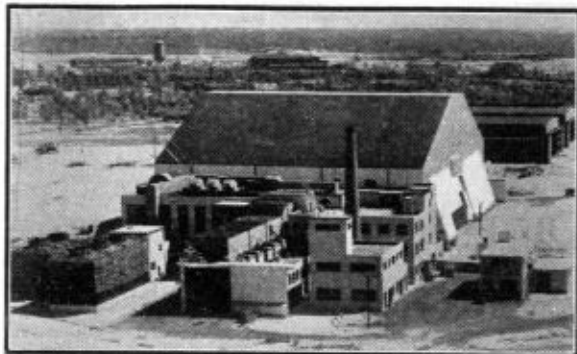

General view of the huge hangar.

closer co-operation with American manufacturers of aircraft and equipment.

His scheme was approved and work started on the climatic hangar. It has now been in continuous use for nearly three years and has saved the U.S.A.F. a lot of time and money. For example, 40 tests were completed in one typical six-week period, compared with 26 finished in Alaska one Winter between September and March. Furthermore, the temperature in Alaska never dropped below -62 deg. Fah., whereas U.S.A.F. requirements call for efficient operation of all equipment down to -65 deg. Fah. Eglin's Climatic Hangar can produce temperatures five deg. colder than that any day of the year.

Nor is that the limit of the hangar's capabilities, for it can produce also gales of up to 100 m.p.h. in combination with sleet, snow, rain, dust, or sand; and at the other extreme, artificial sunlight equivalent to noon-day desert sun.

There is a separate strato-chamber for high-altitude pressure tests; a hot room giving humid temperatures of up to 165 deg. Fah.; a cold test room; another that can reproduce jungle conditions, with tropical rainfall of 12 in. an hour and provision for infesting parts with jungle moulds and fungi; a tropic-marine test chamber equipped with a

salt-spray and rain-making system; and a desert test room. In fact, no matter what the weather is like outside, Eglin can subject men and equipment to everything from a monsoon to an Arctic blizzard.

Let us pay an imaginary visit to the Climatic Hangar to see what goes on there during an average day. The first surprise we should get on arrival is that this £3,000,000 building is only one of many incredible items of test equipment at Eglin Field. The complete U.S.A.F. Air Proving

Ground extends over some 800 sq. miles of the Gulf Coast and contains devices and facilities to test everything from shoe laces to jet-engines and from food capsules to bombers, under simulated battle conditions.

There are 10 aerodromes scattered over the area, "ditching" tests of aircraft are held in the Gulf of Mexico, sea rescues are practised, chemical warfare experiments are carried out, and almost every type of military aircraft can be seen in the skies. Everywhere men are working to search out the faults in U.S.A.F.

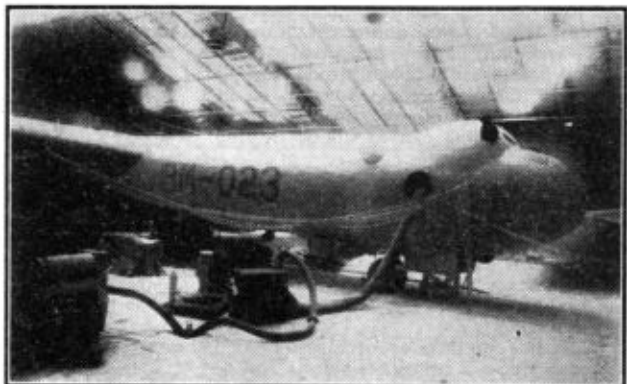

The U.S.A.F.'s Consolidated Vultee B-36, the world's biggest bomber, under test at -65 deg. Fah. The auxiliary heating units at the left force heated air into the pilot's cabin through flexible tubes.

equipment and suggesting modifications to put them right.

The hangar itself is one of the largest single items of equipment at Eglin, with a clear floor area of 250 ft. by 200 ft. and a height of 60 ft. at the centre. Its

insulated main doors weigh 200 tons each and take seven minutes to open, but after donning heavy Arctic suits we can enter the hangar through a small door in the North wall, passing through an air lock which prevents leakage of hangar air.

Look right and then left as you step inside, because motor vehicles can be driven round the hangar to test their efficiency in different climatic conditions. Through the foggy haze over the main floor appear the outlines of seven or eight aircraft, including a "Superfortress," several fighters, a helicopter and a large twin-engined transport, plus a variety of lorries, jeeps, tanks and smaller equipment. It is the "Superfortress" in which we are chiefly interested, for it is being subjected to winterisation tests at 70 deg. below zero.

The engineers conducting the tests obviously disapprove of the cold, but it does not seem to worry the "Superfort." One by one its controls are tested—ailerons, bomb doors, undercarriage, wing flaps—and all work perfectly. Even dummy bombs are dropped into a sand pit below its fuselage. Meanwhile, warm air is being pumped into one of its engines through collapsible canvas ducts, causing a local snowstorm.

After a time the ducts are removed, a mechanic in the cockpit pushes a starter button, and the giant propeller begins to turn slowly. Then the engine bursts into life and the snow gives way to fog, so thick that we can see hardly anything, and hear nothing but the ear-splitting roar of the engine.

When the engine is eventually throttled back and stopped, an eerie silence seems to clamp down on us, rather like a London back-street in a "pea-soup" fog, but not for long . . . without any warning, a sharp burst of machine-gun fire a few feet behind us nearly makes us jump out of our skins. Actually there is nothing to worry about, for nobody has pushed the wrong knob. Special airtight gun-ports open out to one of Eglin's firing butts and permit the testing of fixed and turret guns up to

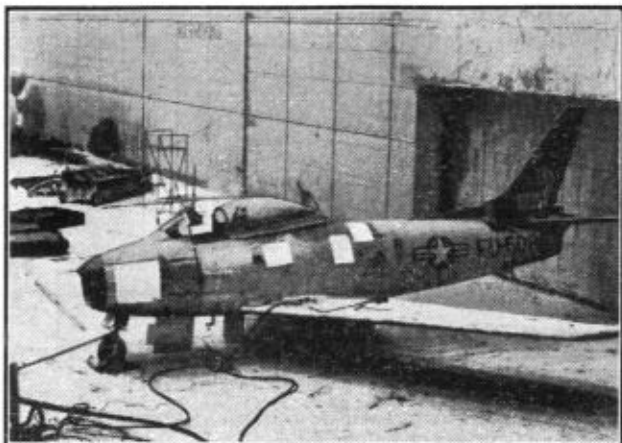

Cold-weather testing a U.S.A.F. North American F-86 fighter. The cables lead to instruments recording the effects of -65 deg. Fah. on the aircraft.

72 mm. calibre on any aircraft inside the hangar in all "weathers."

There is plenty more to see in the Climatic Hangar, but the combined effects of snow, fog, engine noise and machine-gun fire have dampened our enthusiasm by this time, and there is something very attractive in the thought of the nice warm sun shining on the other side of the glass wool-insulated hangar walls. We feel rather like the skunk who got too inquisitive, went into the hangar without an Arctic suit and "froze his plumbing!"

### "Constellation" Air Ambulances for U.S. Forces

Under a new policy American military personnel anywhere in the world requiring medical care in the United States will be flown home, and surface transportation used only for sick or wounded who are unable to be evacuated by air for physical reasons. Patients returned by air can begin specialised treatment from 30 to 90 days before those transported by ocean-going hospital ship.

The flying home of sick U.S. servicemen from Europe began last November. Lockheed C-121 transport aircraft, the military version of the well-known "Constellation" air liner, are being employed.

When used as an air ambulance the seats on one side of the aircraft's passenger cabin are removed, making room for five tiers of four litters each for sick or injured. By this arrangement the machine can carry 20 litter and 20 seated passengers.

# Luxury Bus Travel in South Africa

By Frank Dickinson

**H**OW would you like to ride in a bus capable of 80 m.p.h.? If you lived, as I do, on the route of the South African Railways bus service you could enjoy

Each of the 40 armchair seats is adjustable from an upright to a reclining position. Above the seat, and below the aluminium alloy parcel rack, is concealed an individually controlled reading light. A built-in radio provides excellent reception of news and music.

The floors and side walls are lined with sound-absorbent, fireproof material. The powerful six-cylinder engine, which develops 218 b.h.p. at 2,200 r.p.m., is amidships, on rubber mountings beneath the floor. Even at high speed there is no distracting noise, and most main road gradients can be negotiated in top gear.

An interesting feature in conditions presenting, on occasion, dust-covered country roads, is the provision of a carburettor air intake inside the vehicle.

An air-conditioning plant ensures a complete change of air every three minutes, and built-in heaters serve each pair of seats from long ducts at the floor level. Beneath the seats there is generous room for luggage, and to facilitate its storage and selection a row of lights may be switched on from the (Continued on page 94)



One of the South African Railways luxury buses at Harrismith. Photographs by courtesy of South African Railways.

such a ride every morning and evening. The company's new Canadian-built vehicles, recently put into service on inter-city and long-distance routes, are so speedy and powerful that they will take you into town more quickly than you can drive in your own car, and just as comfortably. And when you arrive you have no parking problem to face; parking is a real difficulty in most of the larger South African cities.

The bus which picks me up at my garden gate is one of several plying between Pretoria and Johannesburg daily, and the trip of some 35 miles is accomplished in an hour, including all stops. Once clear of city streets, the road traverses delightful open country for 15 to 20 miles, and its excellent surface is more than equal to the high speeds of which the new buses are capable.

Perhaps the most pleasing feature of the vehicles is their strikingly modern design. The colour scheme is maroon, relieved with white and silver. They have been specially designed for long-distance journeys, and to provide the maximum passenger comfort.



In the Drakensberg Mountains. The bus shown is capable of speeds up to 80 m.p.h.

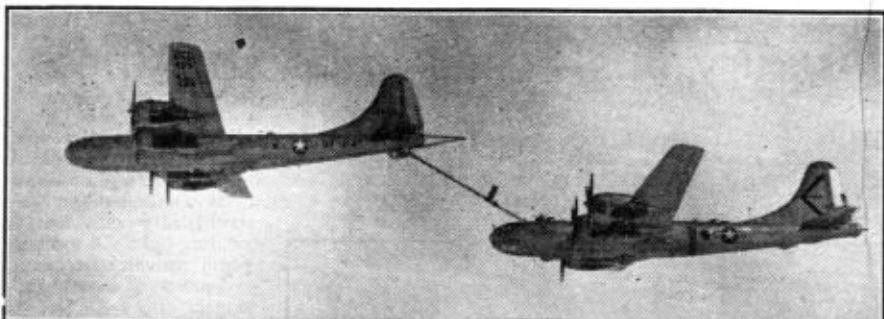

Refuelling an aircraft during flight by the Boeing method described on this page. Photograph by courtesy of Boeing Airplane Company, U.S.A.

## Air News

By John W. R. Taylor

### American Flight Refuelling

As reported in my article on Flight Refuelling in last month's "M.M.", the U.S.A.F. have already adopted Sir Alan Cobham's well-proven refuelling technique for operational use by their Boeing B-50 "Superfortress" Bombardment Groups.

Meanwhile, Boeings have been busy developing a new technique of their own, using a telescopic tubular metal boom instead of the usual flexible fuel hose-pipe. The boom is not carried inside the tanker aircraft, but extends back under the tail like a long deck-landing arrester hook when not in use. In operation, the receiving aircraft approaches the tanker from behind and below, and a technician in the tail of the tanker releases the boom, which pivots downward. He then guides the end into a special socket behind the cockpit of the receiving plane, with the aid of small V-shaped "ruddevator" control surfaces fixed to the boom, after which fuel is transferred through the boom by a pressure-pump system.

### New Jet Fuel

Now that most of the world's air forces have switched over to jet power, somebody has discovered that if there were another way there would probably not be enough kerosene to keep all the bombers and fighters flying. Consequently, as it would cost a fantastic amount of time and money to convert refineries to produce more kerosene, the only

alternative is to convert jets to run on petrol.

The U.S.A.F. have already taken the lead and are converting all their jet planes to burn a newly-developed fuel known as AN-P-58 (Army-Navy Fuel No. 58), which is comparatively economical to produce and has an octane rating of between 50 and 65, compared with 100-130 for high-grade aviation spirit. The change-over has little effect on performance, and has the advantage that the jets could, in emergencies, be run on normal aviation petrol.

Chief disadvantage is that the new fuel lacks some of the safety characteristics of kerosene. It is, therefore, to be hoped that airline operators will insist that engines fitted to their new jet air liners shall burn kerosene, as originally planned, and not any form of petrol.

### No More Air Gunners

Few aviation news items have caused more controversy than the Air Ministry announcement that the R.A.F. are to abolish the trade of air gunner. It raises the age-old question of whether bombers need defensive armament, or whether they can rely on high speed alone to evade enemy fighter defences.

There is much to be said for both schools of thought. The R.A.F.'s unarmed "Mosquito" bombers scored many notable wartime successes; but the Luftwaffe eventually designed fighters fast enough to catch them. On the other hand, American "Fortresses," which fairly bristled with guns and destroyed hundreds of German fighters, often suffered crippling losses before the enemy fighter force was overwhelmed.

An indication of the R.A.F.'s new policy was given by the English Electric "Canberra" jet bomber at the Farnborough Display. Its sleek lines were unbroken by any defensive gun turrets, and its spectacular performance certainly belied the need for guns. It is, in fact, probably fast enough to elude any fighter at high altitudes.

The Air Ministry's decision may mean that they believe the "Canberra," and other still-secret jet bombers now under development, will retain that advantage. On the other hand, they may have a few trump cards up their sleeve in the form of bomber defence rockets, far more accurate and deadly than guns.

### Faster Airmail

A little-known British mail service is the Airway Letter, which is the air

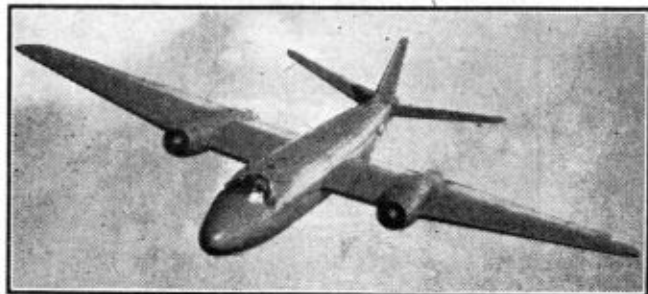

"Canberra," the new unarmed jet bomber. Photograph by courtesy of Aircraft Division, English Electric Co. Ltd.



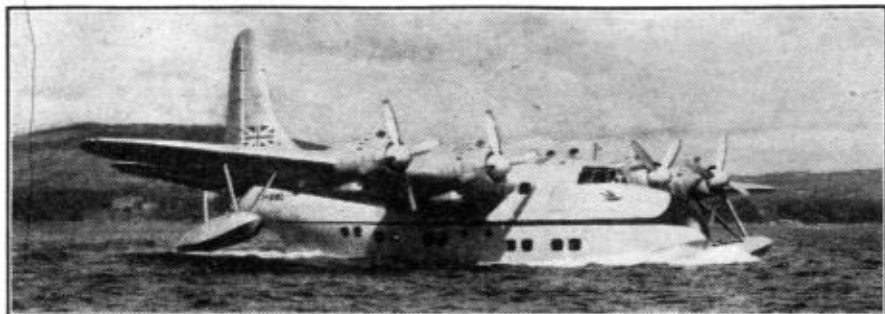

The first of the Bristol "Hercules" powered Short "Solent" flying boats ordered by Tasman Empire Airways. Photograph by courtesy of The Bristol Aeroplane Co. Ltd.

equivalent of the Railway Letter, and can be handed in at B.E.A. booking offices or an airport, just as a Railway Letter is handed in at a Railway Parcels Office.

B.E.A. have been operating Airway Letter services between Penzance and the Isles of Scilly and between Glasgow and Stornoway for some time, and have now extended the facilities to include Manchester, Liverpool, the Isle of Man and Belfast.

This means, for example, that a letter handed in at B.E.A.'s office in Manchester, or at Ringway Airport, in the late afternoon can be collected by the addressee in Belfast the same evening—a saving in time of at least 16 hrs.

Each letter must bear the postage stamps required for normal postal rate, plus an air fee payable to B.E.A., which works out at 5d. for the average letter.

#### Trans-Tasman "Solents"

Tasman Empire Airways have bought four Short "Solent" 4 flying boats for their 1,350-mile non-stop service linking New Zealand with Australia, over the Tasman Sea. They replace the "Sandringham" boats which took over the trans-Tasman service from the famous old "Empire" boats "Avarua" and "Aoteaora," which between them flew nearly two million miles on this route without ever injuring a single passenger.

Between them, the double-deck "Solents" are operating 12 weekly return trips between Auckland and Sydney, on three of which they call *en route* at Wellington, the capital of New Zealand. Each flying boat is powered by four 2,040 h.p. Bristol "Hercules" 733 engines, and can carry 40 passengers on this route, compared with 28 carried by the "Sandringhams" and 19 by the "Empire" boats.

#### Skytyping

A new and more speedy method of skywriting with smoke has been invented by Sidney Pike, President of the Skywriting Corporation of America. The new technique is known as "Skytyping" and requires seven aircraft, all flying in line at the same height, usually 14,000 ft. It involves no tricky manoeuvring or exceptional skill on the part of individual pilots, as all they have to do is fly the aircraft; the rest is done by radio.

The whole operation is controlled by the pilot of a "mother" plane, who flies in the centre of the line, sending out automatic radio signals. These

signals cause puffs of smoke to be released from all seven planes, so timed that the smoke forms letters. Success or failure depends on correctly setting the switches and plugs of the radio controller in the "mother" plane before take-off, for, as Mr. Pike has explained: "One wire plugged in the wrong socket and we write Arabiel!"

He has already made considerable progress with "Skytyping" using seven ex-U.S.A.F. "Harvard" training aircraft, and has reached the stage where his pilots can smoke-write up to 14 letters in well under three minutes.

#### "Neptune" on Skis

A U.S. Navy Lockheed "Neptune" patrol bomber has been successfully test flown at Burbank, California, with 18 ft. aluminium skis fitted over the wheels of its normal tricycle undercarriage. In flight, the skis retract into fairings underneath the engine nacelles and at the nose of the aircraft to reduce drag. For landing on standard runways, the three wheels protrude through openings in the skis, as can be seen in the illustration of this machine on this page.

The use of skis extends the potential operating



With ski-gear extended for landing, the U.S. Navy's specially equipped Lockheed "Neptune" makes its first test flight. Photograph by courtesy of Lockheed Aircraft Corporation.

field of the "Neptune" to include the strategically important Arctic and Antarctic regions, as well as temperate land bases and the decks of the U.S. Navy's largest carriers. Its potential range was demonstrated when a "Neptune" set up the present non-stop World Distance Record of 11,237 miles, in 1946.

A fact of particular interest is that the "Neptune" shown here has what appears to be a rocket gun fitted in its rear turret—the first indication that the U.S. Navy are interested in these advanced and deadly weapons.

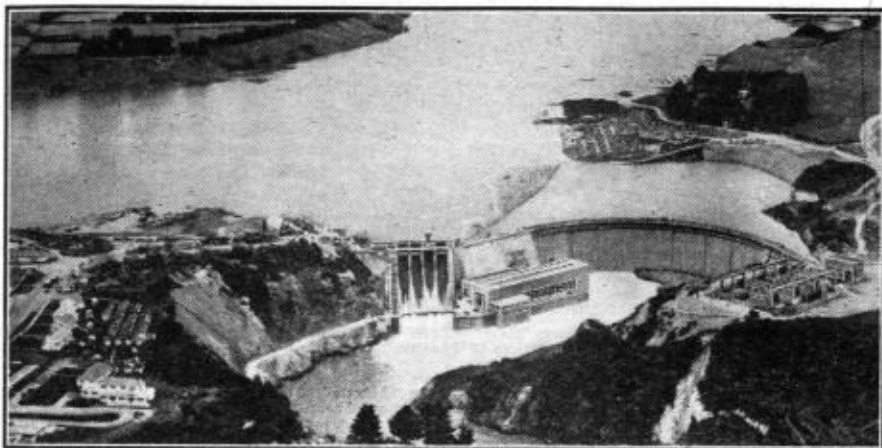

Aerial view of the Karapiro power station, New Zealand. Floating pumice held back by a boom can be seen on the surface of the lake formed behind the dam. We are indebted to the Metropolitan-Vickers Electrical Co. Ltd., Manchester, for the information in this article and for our illustrations.

## A Great New Zealand Power Scheme

### The Karapiro Station in Service

ONE of the most comprehensive schemes now in progress for making use of water power is that of the New Zealand State Hydro-Electric Department for generating current from the flow of the Waikato River, the longest in New Zealand. This is in the North Island, and its length is 220 miles. It rises in the mountainous centre of the country, and its upper waters flow into Lake Taupo, New Zealand's largest lake, a magnificent sheet of water of about the same area as the county of Middlesex in England. From Lake Taupo to the sea, a distance of about 130 miles, the river drops nearly 1,200 ft., and this fall allows for the construction of 10 stations at which it is planned to build dams to store up water. Thus the scheme will develop practically the whole of the power that the river can yield, and it has

been rightly described as an outstanding example of hydro-electric planning.

So far only two of these stations have been built. One was begun at Arapuni nearly 27 years ago and has recently been brought up to full capacity, with eight units developing about 156,000 kW. This station is 30 miles from the mouth of the Waikato, and a second station has now been brought into operation at Karapiro. This will be the farthest downstream of all the stations that are to be constructed, and its turbine runner is only 65 ft. above sea level.

The illustration at the head of this page is a view of the Karapiro Station taken from the air. It will be seen that the dam stretches across the river in a great arch, with an extension in which there is a spillway for surplus water and the intake structure for the power house,

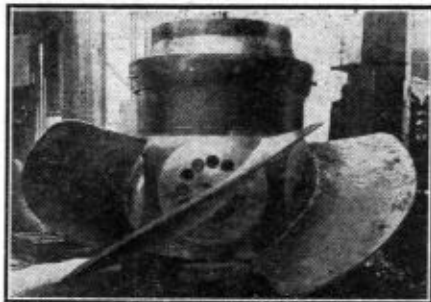

One of the turbine runners of the Karapiro power station.

through which the water used for developing electric power must pass. The power house itself can be seen below the dam, to the right of the spillway section in our aerial view of the station. In making it and the dam 250,000 cu. yds. of concrete were used. The greatest depth of the foundations below the level of the crest of the dam is 222 ft. At their deepest point the foundations are actually 40 ft. below sea level, and the head of water available for power purposes is 100 ft.

Each of the four bays of the spillway is provided with a roller sluice gate measuring 22 ft. by 18 ft., and these as well as the intake gates are lifted and controlled hydraulically. The lake formed behind the dam has an area of about 14 square miles, extending well upstream, and it is interesting to find that its waters have actually submerged an old station that was brought into use 39 years ago.

The power house at Karapiro is 260 ft. long and 60 ft. wide. In it there are three units, each designed to develop 30,000 kW. These are in two sections, the lower one a turbine driven by water from the dam, and the upper one, on the same vertical shaft, the generator. The turbine is of the Kaplan type, which has a higher speed than the Francis type installed in the Arapuni station. One advantage of this higher speed is that the diameter of the generator can be reduced, and correspondingly the length and width of the power station can be made smaller to compensate for the deeper excavation needed for the Kaplan turbine.

The outstanding feature of the Kaplan type of turbine is that the blades are of variable pitch, so that they can be set to the angle giving the highest efficiency possible relative to the guide vane opening. The three required for the Karapiro station are the largest of the type so far built in Great Britain, where they were manufactured by Markham and Co. Ltd., Chesterfield, for the contractors, Bovington and Co. Ltd., London, and one of them is shown at the makers' works in the lower illustration on the opposite page. The efficiency of the turbine depends largely

on the shape and finish of the runner blades, and these were accurately ground to the required shape and given a very high surface finish. The mechanism for the movement of the blades is contained within the hub, and the lower end of the runner is provided with a streamlined conical nosepiece to reduce to a minimum the turbulence of the water as it leaves the blades during operation.

Water for driving the turbines enters the power house through spiral casings surrounding the turbine runner, flowing over the blades to give them the required speed before passing away downward and being returned to the river. The spiral casings for the Karapiro Station were made in New Zealand.

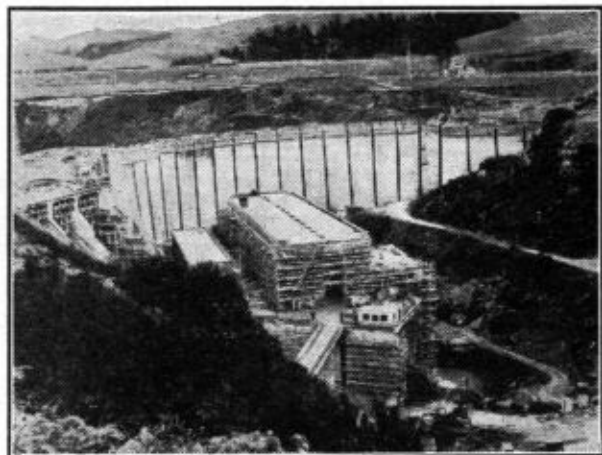

The spillway, dam and power house under construction.

Above each of the turbine runners is the generator, the rotor of which is mounted on the same shaft as the turbine runners. The three generators of the Karapiro station have the largest electrical output of all water turbine driven machines so far built in Great Britain. Each has an overall diameter of 34 ft. and weighs 330 tons. The rotor alone, with the shaft and exciter rotors, weighs 182 tons. The rated output of the generators is 30,000 kW., giving a total of 90,000 kW., and they give three-phase alternating current of 50 cycles at 11,000 volts. They are connected through step-up transformers to the 110 kV transmission system.

The first unit was put into service in May 1947, the second in the following September and the third in May 1948.

# "A.T.C." on the Southend Line

By J. Brooks

THE main line of the former London, Tilbury and Southend Railway, now administered by the Eastern Region, British Railways, is short but interesting. It is just over 40 miles in length, and is the first line to be equipped with an automatic train control system that is worked entirely by magnetism. This system of "A.T.C.," as it is often called, will stop a train after passing a "distant" signal in the "Caution" position should any unforeseen accident happen to the engine crew, and render them incapable of controlling the engine. As this system is worked by magnetic induction there is no contact by the engine with the track equipment; there are no ramps and there are no batteries on the locomotive.

I was recently allowed the privilege of two trips on the footplate of L.M.R. Stanier 2-6-4 tank locomotives to watch this "A.T.C." in operation. The runs took place first in daytime between Barking and Southend, and then in darkness from Barking to Fenchurch Street. After long experiments the system has now been in full use on the line for just over two years.

My first trip was on a Saturday morning on the 10.58 a.m. from Barking; a fast train, first stop Laindon. The engine was one of the first 3-cylinder Stanier tanks No. 42502, built at Derby in 1934. After I first climbed aboard, I was far too interested watching the fireman build up his 200 lb. per sq. in. pressure, and the driver leaning out of his side window for the "Right Away," to notice very much else. Soon the driver drew his head inside, set his gear and opened the regulator and we were off. The three connecting rods turning the driving wheels thrust slowly at first, and the engine

seemed to thump along the line. I could feel the thrusts by a slight side-to-side movement of our engine, which seemed immensely powerful and heavy, especially as we rumbled over the junction just outside Barking station.

We were now beginning to move quickly. The fireman, who had been attending to his fire, adjusted his water feed to the boiler and was now taking a brief sit-down on his seat on the right-hand side of the cab. In two minutes' time he would put in a few more shovelful of coal, for

"little and often" is the golden rule. By this time Upney Station had been passed and we were well on the way to Becontree, quickly passing an Underground electric train that had just left Upney.

I suddenly realised I had not even looked for a signal, and I thought to myself: "What a driver I would make, going past at least six signals without even a glance!" So I began to concentrate on signals and the "A.T.C." system. I realised how a driver must "know the

road." I thought I knew it fairly well, but at the speed at which we were now travelling signals appeared to loom up and flash past before I could think what I should do if I were in charge of the engine. To make it more confusing for me, at every distant signal a horn sounded in the cab; and immediately, it seemed, the signal had come and gone. It was, however, only the strangeness of the first trip that was making things appear difficult. The sounding of the horn was of course part of the operation of the "A.T.C." system.

By the time we were past Dagenham I was beginning to look out for the signals and expect the horn to sound, as I was finding things a bit easier to understand. From my position behind the driver and

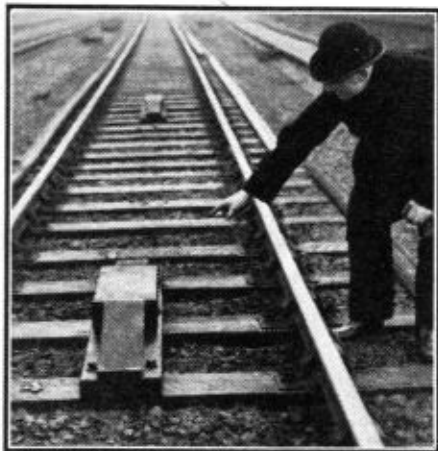

The inductors of the Automatic Train Control system situated between the running rails on the Southend line of the former L.M.S. (L.T. and S. Section).

from his easy way of handling the engine I almost believed that I could have driven it myself. How I longed to be in his place! I did not now notice the heavy rumbling of the 90-ton locomotive and I found I could more easily concentrate on the track.

The object of the Automatic Train Control System is primarily to halt a train before it can over-run a "stop" signal. So by means of a horn sounding in the cab it gives warning to the driver of the position and the aspect of the distant signal—the one he encounters first—with its yellow-and-black fishtailed semaphore. If this signal is in the "on" or "Caution" position the driver knows he may pass it, but he must be prepared to halt at the next stop signal. If the distant signal is in the "off" position, he knows the next signal will give a clear indication.

It is at the distant signals that the ground part of the "A.T.C." installation is laid down. At 200 yards on the approach side of these signals, in the middle of the track, are two boxes with sloping ends, rather like two very little platforms, bolted in the middle of the sleepers. These are the inductors, as shown in the first illustration. In the first box is a permanent magnet, a bar of special steel that has been very highly magnetised. In the second is an electro-magnet. This is a bar of soft iron surrounded by a large coil of insulated wire. Normally it is "dead," for there is no magnetism in the iron, but directly a current of electricity passes through the coil it becomes a very powerful magnet indeed. As soon as the current is switched off the soft iron loses its magnetism and again ceases to be a magnet.

Now every magnet has a north and a south end, known respectively as the north and south poles. The track magnets are arranged so that the engine passes first over the south pole and then over the north pole of the permanent magnet. When it reaches the electro-magnet the opposite applies, so that the engine passes first over the north pole and then over the south pole.

Under the bunker or the smoke-box

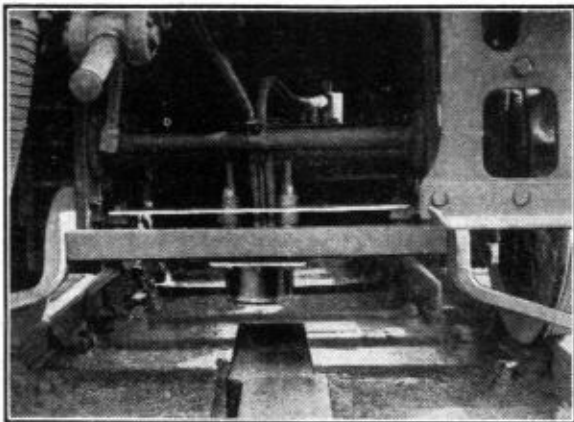

A close-up view showing the receiving apparatus of an engine standing over an inductor. British Railways Official Photograph.

end of the engine is a receiver, placed five inches above the rail level, so it does not touch the magnets. This arrangement can be seen in the illustration on this page. It consists of two iron plates, to which are fixed what look like small iron bridges. These are called pole pieces. There is a gap of a quarter of an inch between the ends of these pole pieces. Between them, pivoted at its centre, is a small but strong bar magnet, so that each end of it can swing up or down to touch the ends of the pole pieces. This moving magnet is called the armature.

Magnetism has certain characteristics and one of them is that a strong magnet, if brought near a piece of iron, will cause that iron to become a magnet also. Another is that the north pole of one magnet will try to push away the north pole of a second magnet. Similarly a south pole of one will try to push away a south pole of another. It is by making use of this repulsion and attraction that the "A.T.C." system works. When the receiver passes over the south pole of a track magnet the pole pieces become magnetised, the curved edge of the lower one with south polarity and that of the upper one with north polarity. This causes the armature between them to move, the north end swinging towards the south pole of the lower pole piece. When the engine passes over the other end of the track magnet the armature swings in the opposite direction.

Connected with the shaft of the armature is a blade which normally covers the end of a pipe forming part of the vacuum brake system and leading to the horn valve.

When the receiver passes over the south end of the track magnet it causes this blade to be pressed hard against the end of the pipe, thus maintaining the vacuum in the brake system so that no air gets to the horn valve and the brakes are kept off. When, however, it passes over the north end, the armature swings right over, the blade is withdrawn from the end of the pipe and air rushes in to destroy the vacuum. At the same time the horn valve lifts and allows the air to pass through and sound the horn. The sound of the horn gives warning that 200 yards away is the distant signal.

If this signal is in the "clear" position, then the second track magnet, the electro-magnet, is made "alive" by a current of electricity from a relay worked by the signal itself. As the electro-magnet is in a position the reverse of that of the permanent magnet, the engine passes first over its north pole and the pipe is kept open; but on passing over the south pole the armature swings over, closes the pipe and the valve, and the horn ceases to sound. So the driver hears only a short blast.

If, however, the signal is in the "caution" position, the electric relay associated with the signal is de-energised, no current passes through the electro-magnet and so it is "dead." Thus the armature in the receiver remains in the open position, air continues to rush in and the horn continues to sound. Soon the vacuum in a small cylinder will be destroyed, lifting the "A.T.C." brake valve and allowing air to pass into the vacuum brake system and apply the brakes.

The driver has to remain in control of his engine himself, however, so to stop the "A.T.C." action he "cancels." To do this he pulls a lever sharply, as he is doing in the picture on this page, causing a magneto to produce a small current of electricity which flows to a small electro-magnet in the receiver. The magnet becomes "alive" and attracts a second blade on the armature pivot, which pulls over the main blade to cover up the pipe end. The horn now ceases to sound, and a black indicating disc above the cancelling lever changes to yellow and black.

This is the reminder to the driver that he passed the last signal at "caution." He will now apply his brakes himself and will be prepared to stop at the next signal. On passing over the next permanent magnet the receiver will open, and as the air rushes in to destroy the vacuum, reduced air pressure behind the disc causes it to be moved backward at the same time, turning it to an all-black aspect again.

It was not until we were almost at Leigh-on-Sea that the first "distant" signal was against us. The horn sounded and went on sounding. The driver reached out for the cancelling lever and pulled it.

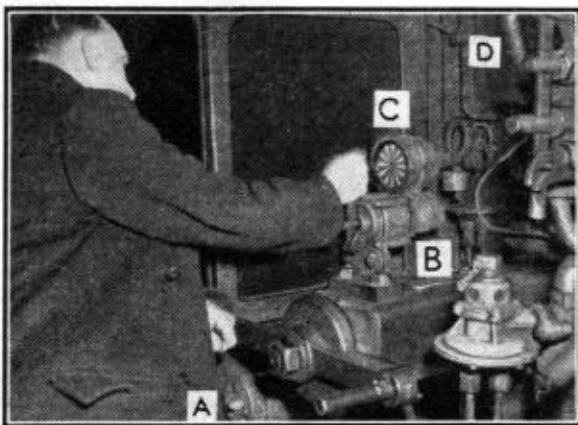

The driver pulling the cancelling lever of the A.T.C. apparatus in the cab. The lettered items are: A, warning horn; B, magneto; C, indicating disc; D, driver's brake valve handle.

At once the horn ceased and the black disc went to yellow and black. He now closed the regulator and then reached up for the brake handle and began gently to apply the brakes. We began to lose speed. The "stop" signal now came in sight, but it was now in the "clear" position; so we steamed slowly past to stop at Leigh station.

On my second trip at night-time, every signal was in the "off" position, so we had a clear run to Fenchurch Street. At every "distant" signal came the short sound on the horn and looking through the cab window I could see its green light.

An important point is that even with "A.T.C." a driver must still observe every signal. In foggy weather, if he has received a "clear" indication on the "A.T.C." he must observe the signal and see that it is "clear." Although (Continued on page 94)

## From Our Readers

*This page is reserved for articles from our readers. Contributions not exceeding 500 words in length are invited on any subject of which the writer has special knowledge or experience. These should be written neatly on one side of the paper only, and should be accompanied if possible by original photographs for use as illustrations. Articles published will be paid for. Statements in articles submitted are accepted as being sent in good faith, but the Editor takes no responsibility for their accuracy.*

### LAKE LUCERNE

Switzerland is noted for its picturesque lakes, of which one of the most famous is Lake Lucerne. While on a school visit to Switzerland during the summer holidays last year I stayed at Beckenried, a small town on the shores of this beautiful lake, which is dominated by the majestic Mount Pilatus, 7,000 ft. in height. This mountain is the one on which is the well-known double rack railway, which is 2½ miles long and has a maximum gradient of 1 in 2.

The lake is only 24 miles long, with Lucerne at one end and Flüelen at the other. The method of travel from one town to another on the shores of this lake is normally by paddle steamer. There is a fleet of steamers, 14 in number, and the time taken to travel the full length of the lake is four hours. This may seem a long time, but it is accounted for by the fact that the vessels stop at various towns and villages on the route. The boats range in size from the "Stadt Luzern," which is of 505 tons and carries 1,200 passengers, to the "Rigi," which is of only 105 tons and carries 200 passengers.

One of the villages at which the steamers call is Rütli. This was where the charter of the Swiss Confederation was signed. About two miles from Flüelen is Altdorf, in the market square of which is a statue of William Tell. It was from the

exact spot on which this is erected that Tell is supposed to have shot the apple from his son's head. The nucleus of the Swiss federation was formed by the three forest cantons of Uri, Schwyz and Unterwalden, surrounding Lake Lucerne. The men of these

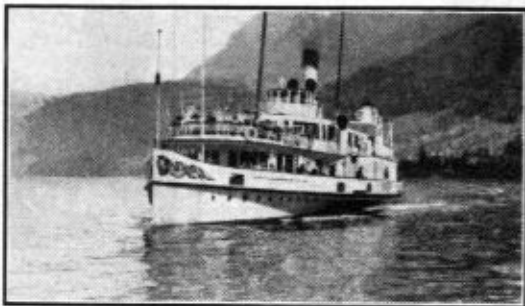

The "Stadt Luzern," a steamer of 505 tons on Lake Lucerne. Photograph by M. Cohen, Stoke Newington.

cantons bound themselves together in an alliance against the Hapsburgs, and it may be said that Switzerland grew around the lake.

M. COHEN (Stoke Newington).

### A FEATHERED FRIEND

Last summer I paid a visit to a friend's farm in the pretty Somerset village of Cossington, near Bridgwater. When walking around under huge horse chestnut and elm trees in the village, I was struck by the amazing number of jackdaws flying around. They seemed to realise strangers were present and were giving us a very noisy welcome.

I noticed one young bird quite close to a group of boys, who seemed to take no notice of it, and it was not upset even by my approach. I asked the boy if it was tame, and the reply was: "Yes, he's John Sparke's jackdaw." What a surprise! That was the name of the boy I was going to visit at the farm. On arrival at the farm I was greeted by "Jack," who flew in ahead right on to his master's shoulder and I seized the opportunity to snap him.

The bird was taken from a nest when only a few days old, and hand reared by John. He has the freedom of the farm, and ignores the farm cats, who seem to have accepted him as one of the household. He accompanies his master on rounds of pig and calf feeding, but is a mischief maker. He steals anything he can carry back to his box, or can hide where neither he nor the farm workers can find it.

Although there are hundreds of his friends flying around all day and calling loudly, Jack seems to prefer the company of humans. My friend is a nature lover and had previously kept a pair of hedgehogs that reared a family. He offered me a jackdaw next spring, but managing such a mischievous rascal in a city would, I am sure, be far beyond my ability and might land me in trouble, so I reluctantly declined. Jackdaws certainly make fascinating pets—if one can cope with them!

ANTHONY HOBBS (Exeter).



John Sparke's Jackdaw. Photograph by Anthony Hobbs, Exeter.

# Using the Meccano Gears Outfit A

## Models for Outfits Nos. 2 and 4

THE new Meccano Gears Outfit A which was introduced recently is a very important addition to the Meccano System. When used with a standard complete Meccano Outfit, especially Outfits Nos. 3 to 6, it greatly increases the interest of the models that can be built. During the next few months we shall describe a number of special working models, each built from a specified Meccano Outfit with the addition of a Gears Outfit A.

Two models are dealt with this month. The first is a Tractor, shown in Figs. 1 and 2, built from Outfit No. 2; the second is the Elevated Jib Crane seen in Figs. 3 and 4, built from Outfit No. 4. In each model Gears from a Gears Outfit A have been included in the construction.

Assembly of the Tractor is begun by bolting a *Magic* Motor into a corner of a  $5\frac{1}{2}'' \times 2\frac{1}{2}''$  Flanged Plate 1. A  $2\frac{1}{2}''$  Strip is bolted to the Motor lever. A Bush Wheel 2 and a Flat Trunnion are fixed at each end of the Flanged Plate and are connected by three  $5\frac{1}{2}''$  Strips. A  $1\frac{1}{2}''$  radius Curved Plate and a  $4\frac{1}{2}'' \times 2\frac{1}{2}''$  Flexible Plate are curved round the front of the Tractor, and space is left between these and a  $2\frac{1}{2}'' \times 2\frac{1}{2}''$  Flexible Plate to allow the

Motor to be wound. Two  $2\frac{1}{2}''$  Strips connect these Plates. A headlamp is represented by a  $\frac{1}{4}''$  Contrate Wheel locked on a  $\frac{1}{8}''$  Bolt.

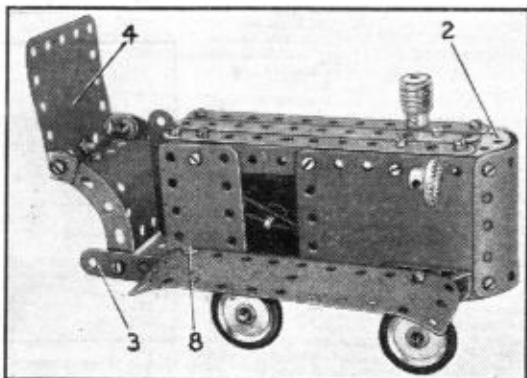

Fig. 1. A gear-driven tractor that can be built from Outfit No. 2 and a Gears Outfit A.

The driver's chair consists of two  $2\frac{1}{2}''$  Curved Strips bolted to Strips 3 and attached by Angle Brackets to a  $2\frac{1}{2}'' \times 2\frac{1}{2}''$  Flexible Plate 4. The seat is represented by a U-section Curved Plate and is attached to Plate 4 by a Reversed Angle Bracket. A  $2\frac{1}{2}'' \times \frac{1}{2}''$  Double Angle Strip 5 is bolted one hole from the end of the Flanged Plate and Strips 3 are attached to it.

A Driving Band takes the drive from the Motor to 2" Rod 6. This Band is twisted once, otherwise the model will move backward. Rod 6 carries also a  $\frac{1}{2}''$  Pinion which meshes with a 57-tooth Gear on Rod 7. The drive from this Rod is taken through  $\frac{3}{8}''$  Sprocket Wheels and Chain to the back axle. The front wheels are mounted in a  $2\frac{1}{2}'' \times \frac{1}{2}''$  Double Angle Strip.

Two  $5\frac{1}{2}'' \times 1\frac{1}{2}''$  Flexible Plates form the track guards and are attached by Trunnions and Angle Brackets. The bolt that holds the guard at 8 is first bolted fairly loosely to the Angle Bracket, the Plate is then placed on the Bolt and finally a second nut is locked in position against

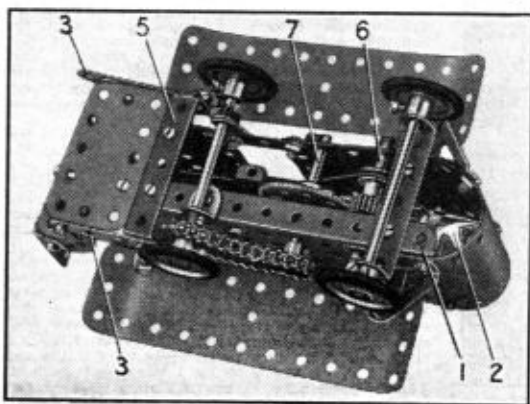

Fig. 2. Underneath view of the tractor.



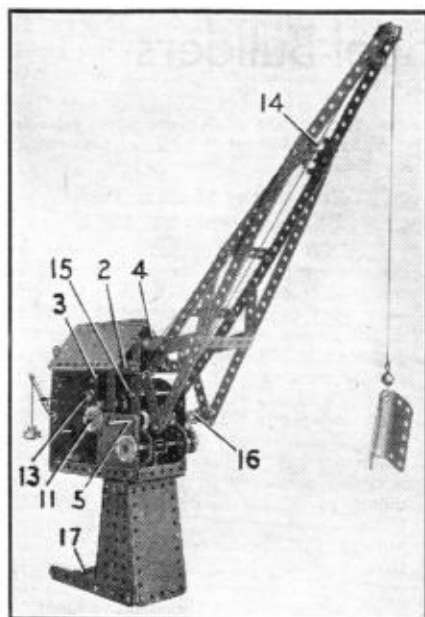

Fig. 3. Outfit No. 4 plus a Gears Outfit A provides all the parts required to build this working model crane. Raising and lowering of the jib and the load are operated through gearing.

it. This allows the guard to be moved aside to permit winding of the Motor.

Parts required to build model Tractor: 3 of No. 2; 5 of No. 5; 1 of No. 10; 8 of No. 12; 2 of No. 16; 2 of No. 17; 4 of No. 22; 1 of No. 23a; 1 of No. 24; 2 of No. 35; 42 of No. 37; 2 of No. 37a; 4 of No. 38; 2 of No. 48a; 1 of No. 52; 2 of No. 90a; 2 of No. 111c; 1 of No. 125; 2 of No. 126; 1 of No. 126a; 4 of No. 155; 1 of No. 176; 1 of No. 186a; 2 of No. 188; 2 of No. 189; 1 of No. 190; 1 of No. 191; 1 of No. 199; 2 of No. 200; 1 Magic Motor; 1 Gears Outfit "A."

The crane shown in Figs. 3 and 4 is begun by building the cab. A  $5\frac{1}{2} \times 2\frac{1}{2}$ " Flanged Plate forms the floor and a No. 1 Clockwork Motor and a  $2\frac{1}{2} \times 2\frac{1}{2}$ " Flexible Plate form one side. The other side and the back are filled in with  $4\frac{1}{2} \times 2\frac{1}{2}$ " Flexible Plates. Two  $5\frac{1}{2}$ " Strips 2 are connected to two similar Strips bolted vertically to the Flanged Plate. The Strips are connected by Angle Brackets to the Plate at the back of the cab and to the Motor by a Fishplate 3. They are braced by two Double Angle Strips, one of which is shown at 4.

The drive from the Motor is taken by 1" Pulleys to Rod 5 which also carries a  $\frac{3}{4}$ " and a  $\frac{1}{2}$ " Pinion. These mesh with either of the Gears 6 and 7, each of which is

mounted on a 2" Rod mounted in the sides of the cab, and in a bearing made by bolting a Reversed Angle Bracket to a  $1\frac{1}{2} \times \frac{1}{2}$ " Double Angle Strip 8. A Rod Connector 9 is attached to the end of Rod 5.

Gear 6 operates the raising and lowering of the load. The drive from Gear 7 is taken to a 3" Pulley 10 on a 4" Rod 11.

To prevent the jib from overrunning, a simple strap brake is made by tying a length of Cord to a  $\frac{3}{8}$ " Bolt 13 and taking it round a 1" Pulley. It is then tied to a weighted lever held in a Rod and Strip Connector lock-nutted to the Motor.

The Strips forming the jib are joined at the head by a Double Bracket and Trunnions 14. The jib pivots on  $3\frac{1}{2}$ " Rod 15, and Angle Bracket 16 limits its downward travel.

Parts required to build the model Elevated Jib Crane: 4 of No. 1; 8 of No. 2; 1 of No. 3; 9 of No. 5; 3 of No. 10; 1 of No. 11; 7 of No. 12; 4 of No. 12c; 2 of No. 15b; 1 of No. 16; 2 of No. 17; 2 of No. 18a; 1 of No. 18b; 1 of No. 19b; 5 of No. 22; 1 of No. 23; 4 of No. 35; 80 of No. 37; 5 of No. 37a; 6 of No. 38; 1 of No. 40; 1 of No. 48; 6 of No. 48a; 1 of No. 51; 1 of No. 82; 2 of No. 54; 1 of No. 57c; 4 of No. 111c; 1 of No. 125; 2 of No. 126; 1 of No. 176; 1 of No. 186a; 4 of No. 190; 2 of No. 191; 2 of No. 192; 1 of No. 198; 1 of No. 212; 1 of No. 213; 1 No. 1 Clockwork Motor; 1 Gears Outfit "A."

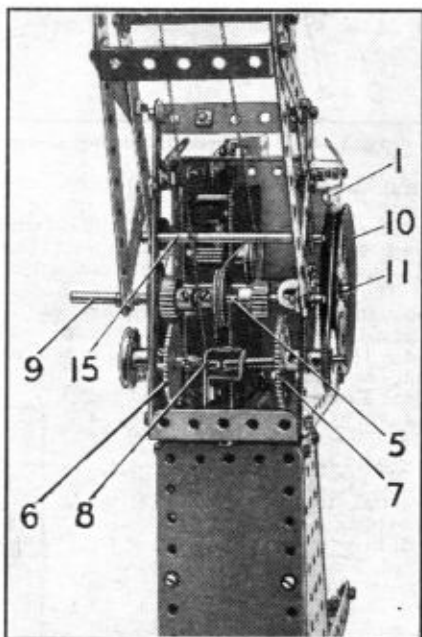

Fig. 4. A close-up view of the crane, showing the gear mechanism.

# Among the Model-Builders

By "Spanner"

## Epicyclic Transmission Gear

The device shown in Fig. 1 is an interesting mechanism designed to provide a

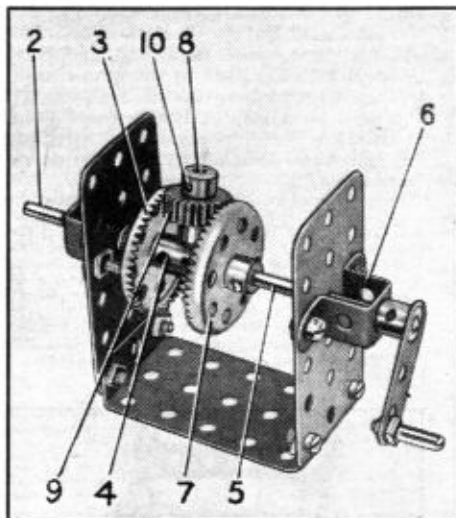

Fig. 1. Compact epicyclic transmission gearing.

gear ratio of two to one between two shafts. Its chief merits lie in the compactness of its construction and in the fact that the driving and driven shafts can be mounted in direct line with each other.

The handle is secured to a Rod 5 mounted in reinforced bearings 6. A second Rod 2 is free to rotate in the boss of a  $1\frac{1}{2}$ " Contra-rotate Wheel 3, and is secured in one end of the Coupling 4. Rod 5 runs freely in the other end of the Coupling and carries a  $1\frac{1}{2}$ " Contra-rotate Wheel 7 fixed in the position shown.

A  $1\frac{1}{2}$ " Rod 8, gripped in the central transverse hole of the Coupling 4, carries a  $\frac{3}{4}$ " Pinion 9, which is free to rotate about the Rod, but is retained in position by a Collar 10. The Pinion is engaged by the teeth of the Contra-rotate Wheels 3 and 7. The Double Bent Strip forming the bearings for the driven Rod is bolted to the Plate by two  $\frac{1}{4}$ "

Bolts, the shanks of which enter holes in the Contra-rotate Wheel 3 and so prevent it from rotating.

## How to Use Meccano Parts

### Toothed Segment (Part No. 129)

The Meccano Toothed Segment is intended principally for use where it is required to rotate a mechanism through only part of a complete revolution, as in the device seen in Fig. 2. To use the Segment it is bolted to a Face Plate or similar part capable of rotating about a centre, and a  $1\frac{1}{2}$ " Gear Wheel is engaged with its teeth. The Segment has 28 teeth and a radius of  $1\frac{1}{2}$ ", so that four Segments can be placed together to form a circle, as shown in Fig. 2. The circle measures 3" in diameter and has 112 teeth. Care should be taken, when joining the segments together, to see that the adjoining teeth are spaced correctly, otherwise they will fail to mesh properly with the driving Gear.

An application for a Toothed Segment is illustrated in Fig. 3, where it is used as

a ratchet for a hand brake lever. The Toothed Segment is fixed to the model by means of a Trunnion in the bottom hole of which a Rod is journaled. The other

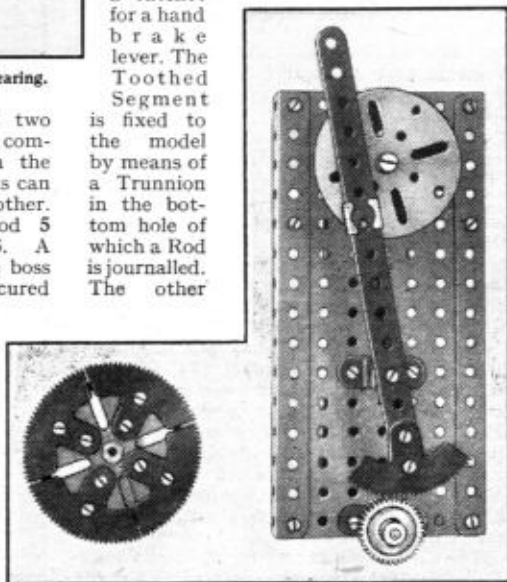

Fig. 2. A Meccano Toothed Segment used to rotate a shaft through part of a revolution.

end of this Rod is carried in a suitable bearing bolted to a convenient part of the model.

#### A Useful Ratchet Brake or Gear Control Lever

The device shown in Fig. 3 is designed to provide a positive method of retaining brake or gear control levers in any required position, and it can be adapted to many models such as cranes and motor vehicles.

It consists of a Toothed Segment 1 bolted to a Trunnion fixed to a baseplate. A Rod 2 passes through this Trunnion, through the end hole of a Strip 3 and through a second Trunnion 4. The Strip 3 forms the control lever. Mounted freely on the Strip is a Slide Piece 5, in the boss of which is fixed a Rod 6. The Rod passes also through a Collar 7 fixed to the Strip but spaced from it by a Washer. A Coupling 8 fixed to the Rod holds a Centre Fork 9. Between the Coupling and the Collar 7 are a Compression Spring 10 and a few Washers. Normally the prongs of the Centre Fork are pressed in contact with the teeth of

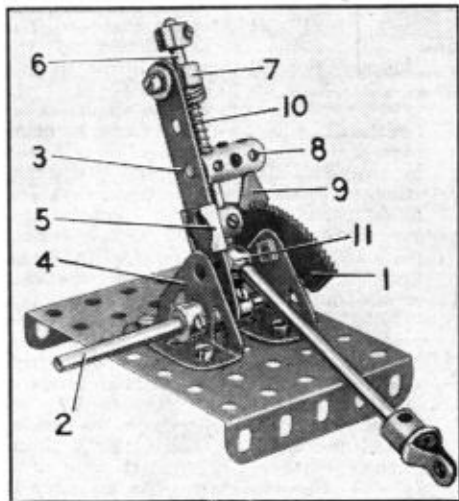

Fig. 3. A novel ratchet brake or gear control lever.

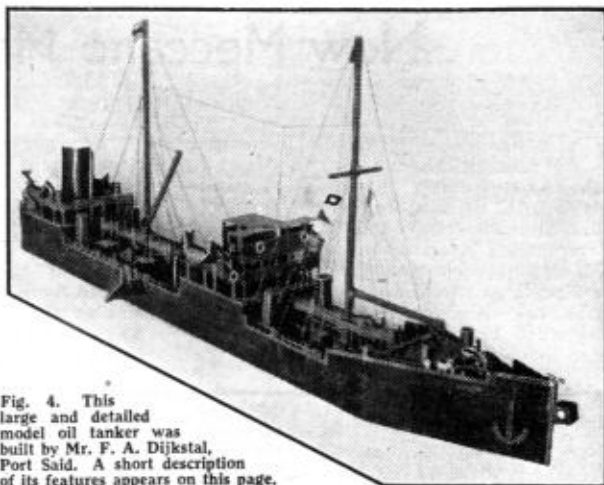

Fig. 4. This large and detailed model oil tanker was built by Mr. F. A. Dijkstal, Port Said. A short description of its features appears on this page.

the Toothed Segment by the action of Spring 10, so that the Strip forming the lever is held in position; but they can be withdrawn by pulling the Rod 6 upward slightly and the lever is then freely movable.

Connection between the control lever and the gear-box or brake gear can be made by means of a Rod fixed in a Hand-rail Support 11 freely lock-nutted to the Strip 3.

#### Egyptian Reader's Model Oil Tanker

From Port Said comes news of an Egyptian reader, Mr. F. A. Dijkstal, who has been busy building the large model oil tanker shown in Fig. 4 on this page. A striking feature of the model is the great amount of detail it incorporates, among the numerous fittings being a steering wheel and compass on the bridge, oil pipes along the decks, navigation lights, anchors, and deck cranes. Many other items of interest also are included and most of them are shown in the illustration. The square box that can be seen at the front of the vessel represents a very powerful search-light of the kind used by ships when voyaging through the Suez Canal by night. Another feature of the model, and one often overlooked by model ship builders, is the inclusion of flags and signals made out in the correct markings.

This model was displayed in the shop window of a Meccano dealer in Port Said, and it attracted considerable attention.

# New Meccano Model

## Fork Lift Truck

OUR new model this month, the realistic Fork Lift Truck shown in Fig. 1 on this page, is built with a No. 6 Outfit. It is fitted with a simple castor steering unit controlled from the driving position. The hoist is operated by turning a Crank Handle mounted at the front of the model.

The chassis is assembled by connecting two  $12\frac{1}{2}$ " Angle Girders together by a  $5\frac{1}{2}$ " $\times$  $2\frac{1}{2}$ " Flanged Plate 1 at the front, and by a  $5\frac{1}{2}$ " Strip 2 at the rear. The

The lower part of the body on each side is assembled on two compound strips 5 and 6. Strip 5 consists of two  $5\frac{1}{2}$ " Strips overlapped three holes, and strip 6 is made from two  $5\frac{1}{2}$ " Strips overlapped four holes. Both compound strips are bolted at the front to a small radius Curved Strip attached to Flanged Plate 1, and at the rear they are connected by Angle Brackets to the Strip 2. The space between Strips 5 and 6 is filled in by a  $2\frac{1}{2}$ " $\times$  $1\frac{1}{2}$ " and two  $5\frac{1}{2}$ " $\times$  $1\frac{1}{2}$ " Flexible Plates. One of the  $5\frac{1}{2}$ " $\times$  $1\frac{1}{2}$ " Plates overlaps the compound strips and is used for the lower part of the curved back of the model. The edges of the Plates are braced by two Formed Slotted Strips.

The bolt attaching strip 5 to the Angle Bracket on Strip 2 holds also a vertical  $2\frac{1}{2}$ " Strip that extends two holes above strip 5. A  $5\frac{1}{2}$ " $\times$  $2\frac{1}{2}$ " Flexible Plate forming the upper side is attached to the  $2\frac{1}{2}$ " Strip, and also to a 3" Strip 7 at the front. The  $5\frac{1}{2}$ " $\times$  $2\frac{1}{2}$ " Flexible Plates on each side are extended by  $1\frac{1}{2}$ " radius Curved Plates 8, and the latter are connected by two  $2\frac{1}{2}$ " $\times$  $2\frac{1}{2}$ " Flexible Plates 9. The Plates 9 are linked to the Formed Slotted Strips at the rear by  $2\frac{1}{2}$ " Strips 10.

The top of the engine cover underneath the operator's seat is made from a Hinged Flat Plate. This is bolted to two  $5\frac{1}{2}$ " Strips, and the Strips are attached to the sides by Angle Brackets. A  $3\frac{1}{2}$ " Strip 11 is used to complete this part of the model, and a  $5\frac{1}{2}$ " $\times$  $2\frac{1}{2}$ " Flexible Plate 12 is attached to the sides by Angle Brackets. The raised dome to the rear of the operator's seat is made from a  $5\frac{1}{2}$ " $\times$  $2\frac{1}{2}$ " and a  $4\frac{1}{2}$ " $\times$  $2\frac{1}{2}$ " Flexible Plate curved to shape and bolted to the sides. A division 13 consisting of a  $5\frac{1}{2}$ " Strip, a  $1\frac{1}{2}$ " Strip and two  $2\frac{1}{2}$ " Curved Strips is attached to the centre of the dome by an Angle Bracket. The top of the model behind the dome is filled in by a Semi-Circular Plate bolted to each side of a  $2\frac{1}{2}$ " $\times$  $2\frac{1}{2}$ " Flexible Plate. The assembly is bolted to a  $3\frac{1}{2}$ " $\times$  $1\frac{1}{2}$ " Double Angle Strip 14 fixed to the rear of the model and to

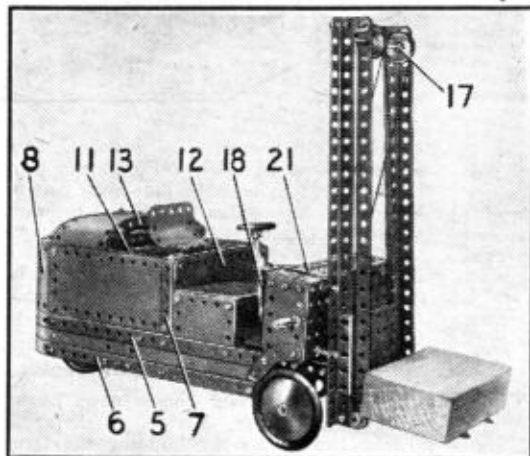

Fig. 1. A fork lift truck that can be built with Outfit No. 6.

front wheels are fixed on a  $6\frac{1}{2}$ " Rod mounted in Flat Trunnions bolted to the chassis, and a support for the rear castor unit is provided by a  $3\frac{1}{2}$ " $\times$  $1\frac{1}{2}$ " Double Angle Strip 3 bolted between the chassis Girders.

The castor unit is made by bolting a Flat Trunnion to each flange of a  $2\frac{1}{2}$ " $\times$  $1\frac{1}{2}$ " Flanged Plate 4. The Flat Trunnions are fixed at the lowest limit of the slotted holes of the Flanged Plate in order to provide clearance for the twin rear wheels. These wheels are fixed on a  $3\frac{1}{2}$ " Rod mounted in the Flat Trunnions and held in position by Spring Clips. The unit is pivoted to the chassis by a  $\frac{3}{8}$ " Bolt passed through the centre of the Flanged Plate 4 and attached by two nuts to the Double Angle Strip 3. Two Washers are placed on the  $\frac{3}{8}$ " Bolt for spacing purposes.

the Hinged Flat Plate.

The floor of the driving compartment is a  $3\frac{1}{2}'' \times 2\frac{1}{2}''$  Flanged Plate bolted at one end to a  $2\frac{1}{2}'' \times 2\frac{1}{2}''$  Flexible Plate fixed to the side. A  $4\frac{1}{2}'' \times 2\frac{1}{2}''$  Flexible Plate 15 and a  $2\frac{1}{2}'' \times 2\frac{1}{2}''$  Flexible Plate 16 are bolted direct to the chassis, and a U-Section Curved Plate, opened out slightly, is used to connect the  $3\frac{1}{2}'' \times 2\frac{1}{2}''$  Flanged Plate to the Plate 16.

The hoist rails on each side are made by joining a  $12\frac{1}{2}''$  Strip to a  $12\frac{1}{2}''$  Angle Girder by Fishplates. The back of the hoist, a  $3\frac{1}{2}'' \times 2\frac{1}{2}''$  Flanged Plate, slides between the  $12\frac{1}{2}''$  Girders and Strips. The rails are attached to the Flanged Plate 1 by  $\frac{1}{4}''$  and  $\frac{3}{4}''$  Bolts. These Bolts are fixed to the rails by nuts, and then attached to the Flanged Plate by two nuts on each Bolt. The upper ends of the rails are joined by a compound  $4\frac{1}{2}''$  strip consisting of two  $2\frac{1}{2}''$  Strips overlapped one hole.

A  $5\frac{1}{2}''$  Crank Handle is mounted in one of the shorter flanges of Flanged Plate 1, and in a Trunnion bolted to the Flanged Plate. Spring Clips are used to keep the Crank Handle in position, and two lengths

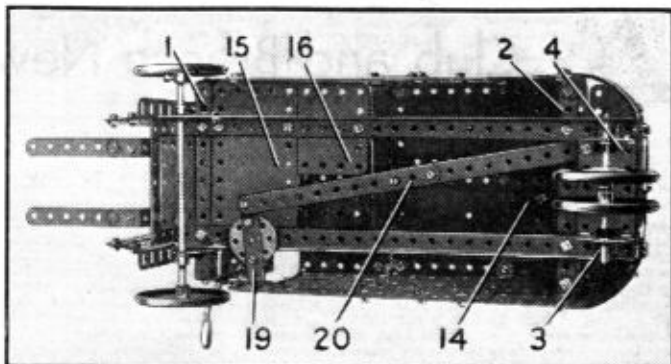

Fig. 2. Underneath view of truck.

of Cord are fastened to it. These Cords are led over  $1''$  Pulleys on a Rod 17, and then fastened to the back of the hoist. It is important to make sure that both Cords are the same length so that the hoist operates evenly.

The steering column is mounted in the chassis and in a Fishplate bolted to a  $2\frac{1}{2}'' \times \frac{1}{2}''$  Double Angle Strip 18. The lower end of the steering column is fitted with a Bush Wheel, and a  $2\frac{1}{2}''$  Strip 19 is bolted across the Bush Wheel. Strip 19 is connected by a compound strip 20 to the castor unit, and lock-nuts (Cont. on page 94)

## OUTFIT No. 3 MODEL-BUILDING CONTEST

The winter model-building season is now in full swing, and we hope every reader will take the opportunity of sending in an entry for our latest model-building competition. One of the most successful of last year's competitions was the Outfit No. 4 Contest first announced in the March issue of the "M.M."; this month we announce a similar Contest for models built with Outfit No. 3. Entrants are free to choose any subject they wish for their models, but they must not use any parts other than those included in a No. 3 Outfit, and models must be the unaided work of competitors.

Each competitor is asked to send a photograph or a sketch of his completed model, together with a list of parts used in its construction. A few brief notes covering any points not shown fully in the illustration should also be sent, and the competitor's age, name and address must be written clearly on the back of each illustration submitted.

Entries should be addressed: "Outfit No. 3 Model-Building Contest, Meccano Ltd., Binns Road, Liverpool 13."

There will be two sections to this Contest, for Home and Overseas readers respectively. Entries in the Home Section must reach us by 31st March; Overseas entries will be accepted up to 31st July next.

The following prizes will be awarded in each Section: First, Cheque for £3/3/-; Second, Cheque for £2/2/-; Third, Cheque for £1/1/-; There will be also five prizes each consisting of a P.O. for 10/6, and five prizes each of a P.O. for 5/-.

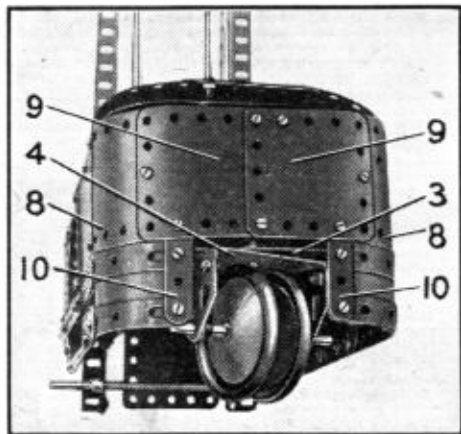

Fig. 3. End view of the truck.



# Club and Branch News



## WITH THE SECRETARY

### A CLUB PROGRAMME SUGGESTION

Some months ago I suggested the planning and construction of a Dinky Toys layout as a suitable feature for the programme of a Meccano Club or a Branch of the H.R.C. How thoroughly this suggestion has been taken up can be gathered from the Club reports on this page, for of the four Clubs the recent proceedings of which are described three have actually built a scene of some kind in which Dinky Toys can be used. One scene is an airfield from which a complete Dinky Toys Airway system is operated. Another is a model town that clearly is on the coast, for the Dinky Toys required for its operations include ships. The third is a road layout that shows how valuable Dinky Toys layouts may be for purposes that at first would be thought far removed from fun and games, for it is to be shown at an Exhibition organised to further the campaign for road safety.

I hope that other Clubs and Branches will follow this lead. There is no lack of possibilities, but there must be a specific aim in view and a definite plan must be laid down at the start if real success is to be achieved. Branches can make particularly good use of Dinky Toys layouts in association with the Hornby or Hornby-Dublo layouts. For instance, the goods yards of a model railway layout are well adapted for the use of such Dinky Toys as the Coles Mobile Crane, which is invaluable for exchanging loads between railway wagons and the road lorries on which they are collected or delivered.

### BRANCHES RECENTLY INCORPORATED

- B.515—BEDDINGTON CRUSADERS—A. A. L. Lockett, Emmaus, Oakley Avenue, Beddington, Surrey.  
 B.516—TETTENHALL COLLEGE—Mr. F. J. Rose, Tettenhall College, Tettenhall, Staffs.  
 B.517—HIGH CRAIGIE—R. C. Stewart, 5, Squire's Cottages, Craigie Knowes Road, High Craigie, Perth.  
 B.518—REDDIFORD SCHOOL—W. H. White, Reddiford School, Cecil Park, Pinner, Middlesex.  
 B.519—MEEKATHARRA—A. J. Siebel, Box 34, Meekatharra, Western Australia.  
 B.520—BIRCHINGTON—Mr. D. A. J. Mandeville, 36, Albion Road, Birchington, Kent.

### PROPOSED CLUBS

- SCOTLAND—J. G. Todd, 86, Comrie Street, Sandyhills, Glasgow E.2.  
 NEW ZEALAND—Mr. V. F. Murray, P.O. Box 11, Papatoetoe, Auckland.  
 CARDIFF—Mr. N. C. Whitehead, Central Young Men's Christian Association, opp. Queen Street Station.

## CLUB NOTES

NEWBURGH (NR. WIGAN) M.C.—At one meeting a Merry-go-round was built and set in motion. At another an airfield was constructed, and an airways system operated with Dinky Toys Aircraft. Hornby Railway Nights are arranged and Games are played. Visits have been paid to the Edge Hill (Liverpool) locomotive shed and to H.M.S. "Cleopatra" in Liverpool Docks. Club roll: 12. Secretary: K. Long, Gwendor, Course Lane, Newburgh, Nr. Wigan, Lancs.

NEWTOWN SCHOOL (WATERFORD) M.C.—This enterprising Eire School Club has made a great success of an Exhibition, the central feature of which was a

model town, a seaport, with a Lifting Bridge, Eiffel Tower, Farm Implements, ships and other models. Plans are now being made for a further Exhibition open to the public. At meetings the Club room is very busy and extensions are now being planned. Club roll: 17. Secretary: A. Rowntree, Newtown School, Waterford, Eire.

HUNTINGDON M.C.—Intensive model-building and other work continues, and visits to local works and railway stations are very popular. A special feature has been the construction of a fine Dinky Toys road layout, built for an Exhibition organised by the County Road Safety Organisation. A Hornby-Dublo railway system is now under construction. Club roll: 55. Secretary: Miss J. Stocker, Offord Darcy, Hunts.

TYNECASTLE SCHOOL (EDINBURGH) M.C.—Members are keen on model-building and many fine advanced models are constructed at meetings. Interest is being taken in Photography, and completed models are to be recorded by the members of the Photographic Section. Plans are being made for a Parents' Night. Club roll: 39. Secretary: J. Nisbet, 17, Glendevon Park, Edinburgh 12.

## BRANCH NEWS

SLOUGH—Good progress is being made with the layout and constructional work. An experimental signal has been made, a locomotive is under construction and a passenger coach is being built from balsa. The outdoor track, previously on ground level, is being laid on trestles 2 ft. 6 in. in height. Secretary: W. Eisele, 335, Farnham Road, Slough.

DURHAM SCHOOL—Additions have been made to the Branch rolling stock. The layout has been completed and good operations are now in progress. Membership is growing satisfactorily, and plans are being made to decorate the Club room. Secretary: G. M. Fordy, School House, The School, Durham.

WEYMOUTH AND DISTRICT—The track is being provided with more realistic scenery, and the main line is to be doubled. There is room for more members and those interested should get in touch with the Secretary: V. E. James, 82, Wyke Road, Weymouth.



Meccano and Hornby Train enthusiasts who were present at the inaugural meeting of the Meekatharra (Western Australia) Branch No. 519. This Branch was founded by Mr. A. J. Siebel, who acts as Secretary, and Mr. E. P. Campbell is Chairman. The construction of an extensive Hornby Train layout is now in progress.

## Dinky Toys on Hornby Layouts

THE aim of the Hornby railway owner should always be to make his line and its surroundings as realistic as possible. Meccano Dinky Toys and Supertoys used in conjunction with the railway can help a great deal towards realistic effects. If, for example, we have a station without any road vehicles near at hand, it will give the impression that nobody uses the railway. But the scene will "come to life" if we have a few cars parked in the station yard, a Royal Mail van and a taxi or two waiting for the trains that stop at the station. Modern cars such as Dinky Toys 40a Riley Saloon, 40d Austin "Devon," and 40c Standard "Vanguard" are splendid for this purpose; while the Royal Mail Van 34b, and the Taxi 36g, are old favourites.

The roads, actual or imaginary, that run alongside the track and elsewhere should also have motor vehicles placed along them. If we have a Hornby Level Crossing on our railway a very realistic scene can be made by placing cars and lorries on each side of the gates waiting for the train to pass. Included in such a traffic "queue" there could be some of the Supertoys such as the various Foden vehicles, Supertoys 501-4.

Apart from their general use, many Dinky Toys and Supertoys are excellent in connection with freight traffic. The illustration on this page shows a busy scene at a goods station. Note the Coles Mobile Crane, Supertoy 571, which is lifting a bale out of the Hornby Open Wagon. Such bales can be made from small pieces of cloth tied up with Meccano Cord or string so that they can be slung from the crane hook. The B.E.V. Electric Truck, Dinky Toys 14a, also shown in our illustration, is a very useful vehicle for any goods station.

For the handling of goods and miniature bales or cases, the Coventry Climax Fork

Lift Truck, Dinky Toys 14c is an interesting appliance. It can be used to good purpose where loads have to be lifted and stacked.

The Dinky Supertoys lorries can be used effectively in Hornby goods yards as they closely correspond to the usual Gauge 0 scale. The Guy Flat Truck, Supertoy 512, is particularly useful for railway service. Its flat deck allows it to take almost any type of load, and it has the special advantage that the Containers

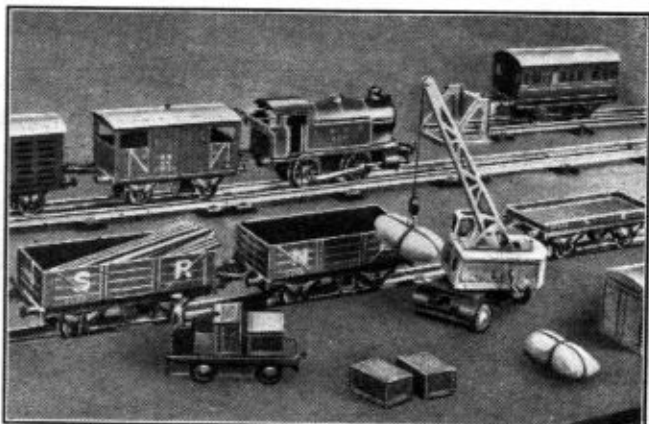

Goods loading in progress on a Hornby layout. The Coles Mobile Crane, Supertoy No. 571, and the B.E.V. Electric Truck, Dinky Toy No. 14a, are prominent.

of the Hornby System, which travel by rail on Hornby Flat Trucks, can be accommodated on the deck. The Bedford Articulated Lorry, Supertoy 521, can handle a good load and by reason of its articulated construction it can be manoeuvred forward or backward in order to reach the exact position required by the "driver."

In addition to their use on the roads, certain Meccano Dinky Toys make realistic loads for railway wagons. For instance, we can load vehicles like the Aveling Barford Diesel Roller 25p, the Massey-Harris Tractor 27a, and the Massey-Harris Manure Spreader 27c on Hornby Flat Trucks. These can be covered with miniature tarpaulin sheets which are easily made from any suitable brown or black material. The sheets should be tied in place with string or cord from each corner to the wagon buffers.

# The Hornby-Dublo Isolating Rail

IN the last two issues of the "M.M." these pages have dealt with the Hornby-Dublo Uncoupling Rail. This month we deal with another important component of the Hornby-Dublo System, the Isolating Rail and its attendant Switch, and make some suggestions for its use.

The object of Hornby-Dublo Isolating Rails is to allow a layout to be divided into separate sections that can be made "alive" or "dead" as desired; that is to say, current can be fed to, or cut off from, such sections as required by traffic operations. This is a great convenience when, as a layout expands, there is more than

these sections of conductor rail is connected to terminals that project from the track base. These terminals allow the Isolating Rail to be connected up to the terminals of the Switch.

The simplest application of the Isolating Rail and Switch is found in situations such as that shown in the first illustration. Here we have a main line on which a Hornby-Dublo express is running while a freight train stands in a siding that includes an Isolating Rail. This is a dead-end siding; that is, it is terminated by a Buffer Stop, so that a single Isolating Rail and Switch is all that is required.

The Isolating Rail is the first straight rail in the siding, and that part of the siding between it and the Buffer Stop forms a separate electrical section. The terminals of the Rail are connected to the terminals of the Switch as detailed in the instructions. While the Switch lever is "off" no current passes through the Switch to the section of track

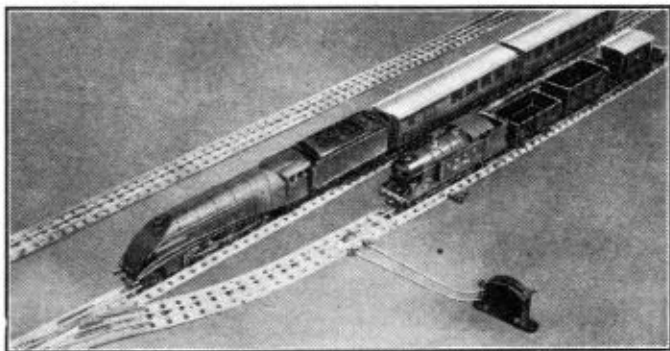

The Hornby-Dublo Isolating Rail and Switch in use. A goods train is held on an isolated section in the siding while an express passes by on the main line.

one engine or train to be dealt with. On a single track with one Dublo Transformer and Controller, only one engine or train can be run at one time; without Isolating Rails, the others would have to be off the track altogether and much fun and realism would be lost. With Isolating Rails in use, however, these other engines or trains can be held in sidings or loop lines forming sections that can be cut off electrically from the main track.

The Isolating Rail resembles a standard Hornby-Dublo Straight Quarter Rail, EDB1 $\frac{1}{4}$ ; and it is the same length, 2 $\frac{1}{2}$  in., as this Rail. The centre or conductor rail of the Isolating Rail is not continuous but is divided into two sections by a length of insulating material forming an electrical gap. This insulating material is arranged to afford smooth passage of the engine collector shoes from one section of conductor rail to the other. Each of

beyond the gap in the Isolating Rail. Therefore the freight train can stand on the dead section thus formed while the express passes along the main line.

Where the trains are required to change places, as will be necessary on a single line so that each may run in turn, additional sections will be required on the main line or in another siding so that one train can be held while the other is moving in or out of the first siding. The arrangements will depend a great deal on the exact form of the layout and requirements of the operator. A good idea of what is necessary will be gathered from several of the layouts that appear in the recent publication "Hornby-Dublo Rail Layout Suggestions" that is now available.

In a loop line, as there are points at each end, two Isolating Rails have to be included. If only one were used the power supply would be continuous on either side



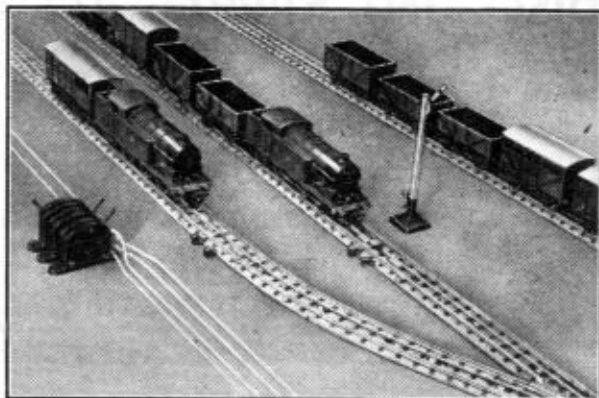

A group of Isolating Switches alongside the track at one end of a loop line. Note the Isolating Rails that are unconnected to Switches.

of the insulating gap. A convenient arrangement is to place an Isolating Rail at each end of the straight section of the loop. It is only necessary, however, to connect one of these Rails to a Switch. It does not matter which of the Isolating Rails is chosen to be connected to the Switch. Normally the one involving the shorter run of wire to the track from the control point would be chosen.

To make the fullest use of the operating possibilities afforded, it is advisable also to divide that length of main line between the loop points into a section as well; and here again, two Isolating Rails are necessary, but only one needs to be connected to a Switch. Trains can be held on either section, main line or loop, each running in turn round the single track main line while the other waits on its isolated section.

It is a great convenience to have the Isolating Switches that control the various sections concentrated near to the usual operating position; that is, fairly close to the Controller. The upper illustration on this page shows several Switches grouped in this way.

The Isolating Rail is particularly useful when used on the tracks serving engine yard premises or even a simple "Loco Road" outside an important station. Then each engine can be made to stand on

its own individual section as required by the operating programme. The different movements must be carefully planned by the operator or he may find that the engine he wishes to move cannot be worked until several others have been shifted.

A specially interesting application of the Isolating Rail is shown in the third illustration. Here the track between the rail and the Buffer Stop forms what is known in miniature practice as a buffer stop section. If the Isolating Rail is used in conjunction with the Uncoupling Rail as shown,

a train can be run in alongside the platform. The engine is brought to a stand so that the leading coupling of the first vehicle has just passed the inner end of the ramp of the Uncoupling Rail. The ramp is now set to operate and a slight setting back of the engine will uncouple it from the train.

As the engine is now standing in the buffer stop section, this section can be made dead. Another engine can now come slowly on to the opposite end of the train and work it away. This type of working is frequently seen at terminal stations, and it is fascinating to be able to reproduce it in miniature. After the train has been worked away the first engine can either move out to the sheds, or wait to work another train.

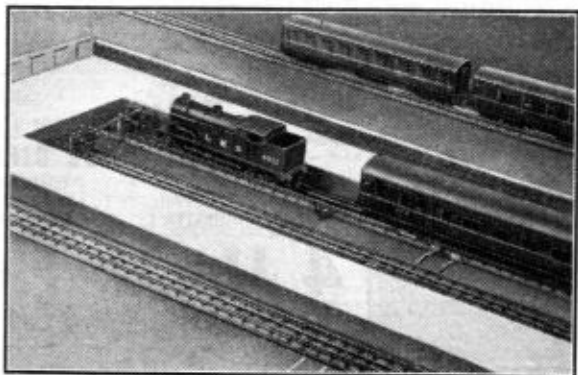

A Buffer Stop section arranged by means of a Hornby-Dubio Isolating Rail used in conjunction with an Uncoupling Rail.

## BARGAIN DISCOUNT APPROVALS

SUPER selections of picked modern and new issues, mint and used for serious collectors, but equally good for sellers and Clubs. Br. Coils. or B.C. and Mixed lots available with book of sets, and a generous discount allowed off purchases. No "stunts" but we DO offer PERSONAL service. "Wants" lists of single stamps welcomed. Approvals are sent ONLY on request, so send with confidence. You'll be delighted with the large and varied selections sent.

Postal Business Only

**THE BIRKDALE STAMP CO. (P.T.S.)**  
104, Liverpool Road, Southport, Lancs.

### SUPER PACKET FREE!



Have you got the large stamp of MONACO portraying the famous collector President Roosevelt with his collection? It is FREE, and the following fine stamps, ARC de TRIOMPHE brought by the Allies to FRANCE when they landed in EQUATORIAL AFRICA, Masaryk of CZECHOSLOVAKIA, also Van Muller of Australia, a one million stamp of inflation, GERMANY, and a pictorial CEYLON. A fine packet and absolutely FREE, enclose 3d. for postage and request approvals and illustrated price list of albums and sets.

Lisburn & Townsend Ltd. (M.M.), West Kirby, Wirral

"DOUBLE TRIANGLE" PKT. —

"DOUBLE TRIANGLE" PKT. —



**FREE!** These grand 2-COLOUR TRIANGLES and 10 other desirable stamps. Just send 2½d. postage and ask to see Special "Mercury" Approvals. Philip J. Dyke (P.T.S.), 35, Buckleigh Ave., London S.W.20

### KING GEORGE VI

A fine packet of unused British Colonials of the present reign from the Cayman Islands, Malta (Self Government Commemorative), the Leeward Islands, Grenada, Burma, Kenya, Uganda and Tanganyika, and the Turks and Caicos Islands sent free to all applicants for approvals enclosing 2½d. postage.

**R. D. HARRISON, ROYDON, WARE**

#### COMMEMORATIVE PACKET FREE!

Many attractive British Colonial and other recent COMMEMORATIVES have just arrived and are yours. HURRY FOR THIS—IT'S FREE! Send 2½d. stamp and request Discount Approvals. HEYWOOD'S, 8, PATON STREET, MANCHESTER 1



### 4 U.P.U. FREE

Inc. large NYASALAND, JORDAN and those illustrated. Free to collectors asking to see my Famous Approvals. Send 3d. to cover my postage and lists. (Without Approvals 9d.) Join 'The Code Stamp Club' Sub. 1/-

**G. L. WRIGHT, (Dept. M.3), Canterbury, Kent**



### The METEOR

#### ILLUSTRATED STAMP ALBUM

The Meteor Illustrated Stamp Album is a large loose-leaf Stamp Album with over 200 pages beautifully printed with short informative descriptions of the various stamp-issuing countries. The album covers the whole world and is divided into continents with a special section for the British Empire. The cover is fully bound in Leather Cloth and extra leaves can be inserted easily where required.

**PRICE 25/-**

This album is available from most stationers and book-sellers, or from the publishers:

#### ERRINGTON & MARTIN

(Dept. 552), South Hackney, London E.9, England  
Established 1880

### FREE! TO ALL COLLECTORS

Sending postage (2½d.) this new stamp for COOK ISLANDS. Bargain—50 China 1/3



**G. P. KEEF — WILLINGDON — EASTBOURNE**

### HALF PRICE APPROVALS

We are offering until further notice special books of GREAT BRITAIN, BRITISH COLONIALS, U.S.A. and AIRMAILS

**at 50% DISCOUNT**

Send Stamp for trial selection.

**SAUNDERS & CO., 8, Hawthorne Ave., KENTON, Mdx.**

### 100 DIFFERENT STAMPS FREE

(including TRIANGULAR and PICTORIALS)

To Approval Applicants enclosing 2½d. postage. **N. JOHNSON (Dept. M.M.), 19, Hillside, Slough, Bucks.**

# Stamp Collecting

## How to Find Stamps

By F. Riley, B.Sc.

LAST month I explained the best way of keeping stamps and displaying them. A problem of equal importance to beginners is how best to get the stamps to deal with, and those who receive a gift of stamps, with or without an album, to start with, will soon find that they wish to add to their collections.

Stamp dealers have made provision for the beginner by arranging packets containing 100, 200, 500 or more stamps, all different, and usually a start is made with one of these, the larger the better. A point to notice here is that an envelope of 1,000 stamps will cost more than twice as much as one of 500 stamps, for the simple reason that it is bound to contain more higher-priced examples.

Whatever packet he gets, the collector will have a really thrilling time examining its contents, sorting out the stamps of the various countries and arranging them in order, and finally mounting them in his album. It is when this pleasant occupation comes to an end that he realises that there are gaps to be filled. If he started with only a small packet he may buy a larger one, or he may be able to get stamps from friends who have correspondents abroad; but these methods will not be productive enough. He must then turn to stamp dealers. He may find



the stamps he needs in the stock of his local dealer and he will certainly explore with keen delight the displays made in the windows of dealers. The advertisements of postal dealers also will be helpful. They usually invite enquiries for approvals, and those who respond receive a little booklet in which various stamps are mounted and priced.

The idea of approvals is that if the collector wishes to buy any of the stamps he removes them from the booklet, which is then returned to the dealer along with a Postal Order to cover the cost of the stamps retained. This should be done without delay, and special care should be taken not to handle the stamps not purchased or to tamper with them in any way. Requests for approvals can be accompanied by notes of the particular countries of which stamps are required. Dealers

will always be friendly and helpful in this respect to genuine collectors.

So far I have said nothing about what should be collected. The usual way is to begin by making a general collection of stamps. This is a good scheme, for while filling up his album the collector will be learning his way about the hobby. One thing he will soon realise is that

to make a complete collection of all the stamps of all the countries that have issued them since the Penny Black appeared over 100 years ago would be a stupendous task, even when costly rarities are excluded.

This need not discourage the general collector, who can go on happily adding to his treasures, but sooner or later he will find that he takes special pleasure in the stamps of certain countries, or in particular types of stamps. In other words he will turn to the idea of a special collection. For instance, he may decide to concentrate on British Empire issues, or he may even restrict himself further and choose certain Dominions or colonies. A favourite plan nowadays is to concentrate on the British Empire stamps of King George VI, and the collector who begins to specialise in these now will have a wonderful time in assembling the stamps of the last 14 years and in covering new issues as they appear.

A plan that is followed by many collectors who have not a great amount of money to spend on their hobby is to set a limit to the value of the stamps they buy. Dealers usually arrange short sets, containing the stamps of particular

issues up to say 1/- in value, and these will be found helpful. Stamps of higher value, if desired, can be bought separately.

The collector will soon realise that it is important to know what stamps there are to be collected. There are several catalogues available, including those of Stanley Gibbons Ltd. and Whitfield King Ltd., and the possession of a good catalogue and careful study of the information given in it will help and interest the genuine stamp collector. With the continual flow of stamps throughout the years catalogues have grown enormously. The large Gibbons catalogue is now issued in parts, and this makes things easier for the collector in special fields. For instance, those who collect British Empire stamps will find that special sections of the catalogue covering these are issued, one for Empire stamps from 1840 to 1936 and a further section listing the King George VI issues. Other sections deal with the stamps of Europe, the United States and so on. Illustrations show stamp designs, and there are also details of watermarks and perforations.





## BEAUTIFUL BERMUDA PACKET FREE

We have great pleasure in offering YOU in addition to YOUR OWN COLLECTION to increase its interest and value, one of the most beautiful stamps ever issued. It is this illustrated **BERMUDA** stamp which depicts various Ships, including a Liner, in Hamilton Harbour, Bermuda (British West Indies). It is printed with centre in black, and frame in red. We will also give to you other stamps also FREE in this packet, including an unusual revolutionary **RUSSIA** showing a Worker, and also a large pictorial **UNION OF SOUTH AFRICA** of great philatelic interest and a fine **FINLAND**.

ALL ABSOLUTELY FREE. Just send 3d. in stamps for our posting costs, ask to see Approvals, and ask for **Beautiful Bermuda Packet Free**. In addition, we will also send you Free something else which you will like. Send now, before you forget and miss this wonderful opportunity to improve your collection.

**WINDSOR STAMP CO. (Dept. M), UCKFIELD, SUSSEX**

## FREE! Amazing New Issue Packet.

### Special Anniversary Offer

A wonderful packet of new and recent issues, including a set of **Indian Archaeological** showing Konarak Horse, Colossal image of Trimurti, The Cosmic Dancer Nataraja, etc.; **beautiful fruit stamp** from St. Thomas, large **Universal Postal Union Commemoratives**, etc. etc.

All these absolutely free—just send 3d. to cover postage and price lists and ask for the New Issue packet.

Write to-day to:

**Capt. MARTIN CAMPBELL & Co.,**  
(Dept. MM)

**58, High Street, Watford, Herts.**

## COLUMBUS AND CHINESE AIRMAIL



## FREE!!

2 Very Large Scarce Commemoratives will be sent **ABSOLUTELY FREE OF CHARGE** to every collector or who asks to **SEE** our Approvals.

A 1893 **UNITED STATES** stamp, in honour of the 400th Anniversary of the Landing of Columbus; and a scarce 1948 **CHINESE AIRMAIL**, surcharged 10,000 dollars, and unused. Don't Delay. Write to-day! (Enclose 2½d.)

**D. J. HANSON** (Dept. M.M.46)  
Eastrington • Goole • Yorks.

## FREE GIFT OF STAMPS

to every applicant for approval books. The GIFT contains 30 British Colonials including 8 K.G. VI mint—no Great Britain. Good discount is given and a list of 98 Gifts is sent. These can be chosen by you and vary in value according to the money sent for purchases. They include K.G. VI; Silver Jubiles; ALL the Colonial Victory sets mint; and Foreign stamps. 3d. postage please.

**C. A. RUSH, 38, Queen's Avenue, Whetstone, London N.20**

## MANY THOUSANDS OF STAMPS —FOR SALE!

SEND for a selection on approval. I give to each applicant 20 stamps including new Gold Coast, Turks Is., Basutoland, S. Rhodesia, Barbados, etc.

**WITHOUT APPROVALS 9d.**

**S. H. FLEMING, Newhaven, Glyn Avenue, Colwyn Bay**



## FREE!

This fine packet of Br. Colonial U.P.'s to all requesting our famous approvals and enclosing 3d. stamp.

**FRANCIS CURTIS & CO. LTD. (DEPT. M.Z.)**  
226, BAKER STREET, LONDON N.W.1

**FREE—STAMPS CATALOGUED 5/-**  
to applicants for 4d. approvals  
**COX, 17, STONELEIGH PARK ROAD, EWELL**

## FREE FINE IUME

How many stamps have you of this Old Town on the Adriatic? None! Well here is your opportunity. Five fine large Fiume FREE with any one or more of:—10 Cuba 6d., 50 Turkey 1/3, 50 Colombia 2/6, or with approvals. Enclose postage. Dealers supplied. Oversea agents wanted. Price list FREE.

**ASTLEY & CO. (M)**

**103, CADMAN CRESCENT, WOLVERHAMPTON**

## DOWN YOUR WAY

Whilst we give a free gift of stamps to ALL applicants for our popular approvals, who enclose 2½d. postage, for **THIS MONTH ONLY** we will give an **EXTRA** gift

to those who live in—**LANCASHIRE, SHROPSHIRE, NORFOLK, PERTSHIRE**

Watch this advert

We may be down **YOUR** way next month

**GEM STAMP CO. (Dept. M)**

"Leewards," Glastonbury Chase, Westcliff, Essex

## ALL-NATIVE PACKET FREE!

**LARGE PICTORIALS — BEAUTIFUL SCENES**  
Stamps portraying tropical life  
**WITCH DOCTORS — WARRIORS — DESERT JUNGLE — PALM TREES — MOUNTAINS WILD LIFE — VILLAGE SCENES**

Another "John Richards" packet of marvellous stamps offered FREE to applicants for Discount Approvals. Enclose 3d. stamp for postage; etc. please. **John Richards (MM), 292, Robin Hood Lane, Birmingham 28**

## FREE "WORTH WHILE" OFFER

Three really good stamps cat. 6/6

Free to all applicants who send 2½d. for postage and ask to see a selection of my "WORTH WHILE" approval sheets. You will be pleased, I know.

**JOS. H. GAZE, 10, Pimlico Road, CLITHEROE, Lancs.**

For other Stamp Advertisements see also pages 88 and xv.

# Stamp Gossip

## and Notes on New Issues

By F. E. Metcalfe

TRY as one may, it is still almost impossible to get away from the ubiquitous "Universal Postal Union" stamps, or "U.P.U.s" as collectors familiarly call them. Practically every country has issued a set and it has been most interesting to note the various tastes of the different nations. The stamps are by no means typical of the art of the countries that issued them, for many went abroad to get them printed. He would be a bold person who would essay to judge which set is the most beautiful. Alas, few would give more than an odd mark or two to our own stamps.

Let us change the subject and get back to the bread and butter stamps, those issues that are always with us. These fancy sets are all very well, but one gets tired of them in time, and it is those real stamps, produced for paying postage and not to catch collectors' pence, which give the most lasting pleasure.

Many readers will no doubt have noted that, in the latest edition of Gibbons' K.G. VI catalogue, Egypt, Iraq, Transjordan and Burma have been transferred to the foreign portion. Now it is announced that Irish stamps are to be similarly treated, and collectors of the stamps of these particular countries will be wondering what effect the change will have on the value of their stamps.

Let us take Egypt first. This country has always been very popular, for it has produced so many beautiful issues, and if it continues to issue handsome stamps there is no reason why it should suffer at all. Incidentally, an attractive commemorative was recently brought out to celebrate the abolition of "Mixed Courts." In the past special courts were held to try foreigners, and now these have most rightly been done away with.

Transjordan and Iraq will probably suffer somewhat, so will Burma, but this country would have declined in popularity whether it had remained in Gibbons' Part I or not. It was already losing in popularity in fact, for substantial quantities of Burmese stamps were coming on the market from goodness knows where, and were already selling



while the going is good.

Regarding Eire, or the Republic of Ireland as it is now called, it perhaps won't make much difference, for Gibbons' Catalogue does not circulate to any degree in the U.S.A. and it is there that the majority of collectors of stamps of the sister isle reside. Perhaps Gibbons are going a bit ahead of themselves



large sums on stamps. The other week the writer of these notes saw a collection of them formed by a junior who had not spent more than 30/-, including the cost of a 12/- album, and the result was charming. All the commemoratives were there, in nice used copies. The collector had not bothered about the overprinted issues.

Such a collection only costs a copper or two a week to keep up to date. If any reader would like to start one now let him begin with the definitive issues which appeared after 1922, and he will find that a nice little collection can be formed with very little outlay. But be sure and only take good copies; have nothing to do with those that are heavily cancelled.

Many readers will be interested in the Football Championship to be held in Brazil in summer. Will we win it? Let's wait and see. One thing is certain, the team that does win will have to work hard, for not only is football very popular with South Americans, but they play very well, and if they can

manage it the Cup will remain over there. The writer of these notes has watched a lot of football in Brazil, Argentina and Uruguay, and has played the game there. He was always struck by the skill shown by the various teams. Proof of their quality is provided by Uruguay, who have twice won the football event in the Olympic Games. Even small countries like Guatemala will take a lot of beating. The stamp of this country we are illustrating is quite topical. Readers will be amused at the rig of the footballers depicted; the players seem to be got up in bathing slips rather than the Alec James type of pants.

A reader writes to say that he has two 1 sol stamps of Peru, one narrown and the other deep brown, and he wonders if something has happened to one of them to change the colour. The answer is no.

These stamps are part of an interesting set. Some years ago Waterlow and Sons Ltd. produced a set of stamps for Peru, and later an American firm of printers took over the work. Now Waterlows have again got the contract. The designs remain the same, but the colours are being changed somewhat, and what this reader has got is a copy of each of the two printings, old and new.

And now a tip for those with a few shillings to spare. Gibbons have raised the price of the 1/- Australia No. 174 to 15/-. This stamp was mentioned as worth buying when it was catalogued last year at 3/6. Now, you will say, it has gone up. Yes, but it is still too cheap, and inside two years it will probably sell at £2, if not more. It is worth that too. But the stamp is only scarce mint; examples in the used state are common enough.

over this change, for surely Ireland is still an associate member of the British Commonwealth of Nations, and whether she is or not, her stamps are well worth collecting, particularly by those who cannot afford



# Competitions! Open To All Readers

Prize-winning entries in "M.M." competitions become the property of Meccano Ltd. Unsuccessful entries in photographic, drawing and similar contests will be returned if suitable stamped addressed envelopes or wrappers are enclosed with them.

## Look at this Railway Scene



The illustration on this page, a railway scene, shows a good variety of railway equipment. Some parts of this have been distinguished by numbers and readers are invited to name these and to explain their purpose. The items should appear on entries in the order in which they are numbered. Competitors are asked to write on one side only of each sheet of paper used, and they are reminded to be careful to see that their names, ages and addresses also are given. Entries should be addressed "February Railway Con-

test, Meccano Magazine, Binns Road, Liverpool 13."

There will be two sections in the competition, for Home and Overseas readers respectively, and in each there will be prizes to the value of 21/-, 15/- and 10/6. There will also be Consolation Prizes for other deserving efforts, and in the event of a tie for any prize the judges will base their decision on the novelty and neatness of the entry. The closing dates are 31st March in the Home Section, and 30th June in the Overseas Section.

## Detective Work

Below we give a passage from an article in this issue of the Magazine that has been disguised by substituting other letters for those actually used. The substitution has been made on a very simple plan, and sharp eyes should have no difficulty in detecting what this plan is.

Mic md rfc kmqr amknpefcagtc qafckq lmu gl nmpccq dmp kyigle sqc md uycrp nmucp gq rfyr md rfc Lcu Xcyjylb Qryrc Fwbpm-Ujcarpga Bcnyprkclr.

Entries should give the sentence in full, with the number of the page on which it appears in the Magazine, and should be addressed "February Code Puzzle, Meccano Magazine, Binns Road, Liverpool 13." As usual, there are two sections, for Home and Overseas readers respectively, and in each prizes of 21/-, 15/- and 10/6 will be awarded for the best efforts. If there is a tie for any prize the judges will take the novelty of the entry into consideration. Closing dates: Home Section, 31st March; Overseas Section, 30th June.

## February Photographic Contest

For the second of our 1950 competition series the subject is an indoor scene or portrait taken in daylight or by artificial light. There is no restriction on the kind of photograph submitted, provided that it was taken indoors by the competitor himself, and on the back of each print the entrant must write his name and state exactly what the photograph represents.

There are two sections in the competition, A for readers aged 16 and over and B for those under 16, and the appropriate section letter must be given on the back of each print.

Entries must be addressed "February Photographic Contest, Meccano Magazine, Binns Road, Liverpool 13." There will be separate sections for overseas readers, and in each section prizes of 21/-, 15/- and 10/6 will be awarded, with consolation prizes for deserving efforts. The closing dates are 28th February in the Home Section and 31st May in the Overseas Section.

# Competition Results and Solutions

## HOME

### SEPTEMBER 1949 RAILWAY CONTEST

1st Prize: C. E. Wrayford, Bovey Tracey. 2nd Prize: P. Gartside, Oldham. 3rd Prize: F. Mills, Kearsley. Consolation Prizes: B. E. Timmins, Birmingham 24; A. Mayor, Keadal.

### SEPTEMBER 1949 HOLIDAY DRAWING CONTEST

1st Prize: R. Oliver, Hemsworth. 2nd Prize: R. Martin, Ewhurst. 3rd Prize: R. Francis, Crewe. Consolation Prizes: D. O'Neill, Keighley; P. Furniss, Sheffield 8; I. V. Wingate, Shirley; L. J. Goad, Newcastle; A. H. Hutchings, Liss.

### OCTOBER 1949 PHOTOGRAPHIC CONTEST

1st Prize, Section A: G. Ogilvie, Edinburgh; Section B: B. Foskett, London S.W.15. 2nd Prize, Section A: P. Lambert, Harrogate; Section B: R. Soper, Gateshead 9. 3rd Prize, Section A: J. D. Porter, Clacton-on-Sea; Section B: M. Wrigley, Dalton Magna. Special Editorial Prizes, Section A: L. Stone, Leeds 7; Section B: P. Clifford, Wembley. Consolation Prizes, Section A: A. R. Brown, Isleworth; A. R. Casebrook, Bletchley; F. G. Reynolds, Sidcup; A. G. Delicata, Ruislip; W. D. Askam, Northampton. Section B: T. Hudson, Wolverhampton; F. Tomney, Old Hill; C. K. Nash, Moreton-in-Marsh; R. Haggas, Apperley Bridge; E. J. Wilson, Pudsey; M. Bayliss, York.

### OCTOBER 1949 CROSSWORD PUZZLE

1st Prize: D. Howe, Glasgow. 2nd Prize: J. L. Wilkinson, Sheffield 11. 3rd Prize: F. Mills, Kearsley. Consolation Prizes: D. N. del Young, Wallingford; R. T. Carpenter, Lancing; J. M. Williams, Kenton, Harrow.

### OCTOBER LOCOMOTIVE NAMES CONTEST

1st Prize: E. P. Goodenough, Enfield. 2nd Prize: A. Peters, Wimscombe. 3rd Prize: T. H. Powell, Birmingham 14. Consolation Prizes: C. E. Wrayford, Bovey Tracey; W. T. Stubbs, Stoke-on-Trent; K. K. Evans, Hesse.

### NOVEMBER 1949 PHOTOGRAPHIC CONTEST

1st Prize, Section A: L. H. Hobbs, Exeter; Section B: P. H. Lamb, Reading. 2nd Prize, Section A: S. L. Connors, New Malden; Section B: B. Foskett, London S.W.15. 3rd Prize, Section A: R. Atkins, Eccles; Section B: Paul R. J. Vickers, Newcastle-Upon-Tyne. Consolation Prizes, Section A: G. Ogilvie, Edinburgh 4; G. P. Clark, Tavistock; Mrs. I. Hardwick, Burnham-on-Sea; D. H. Tomkinson, Wells Green. Section B: B. Worley, Leicester; R. Hardy, Withersnae; R. F. Miller, Purley; F. M. Walker, Uttoxeter.

## OVERSEAS

### JUNE 1949 CROSSWORD PUZZLE

1st Prize: L. R. Dickson, Pretoria, S. Africa. 2nd Prize: C. Harrower, Teralba, Australia. 3rd Prize: G. E. McKinnon, Sydney, Australia. Consolation Prizes: W. Armstrong, Auckland, C.1, N.Z.; L. Phillips, Westport, N.Z.; Miss T. Rajeswari, Vellore, South India.

### JULY 1949 PHOTOGRAPHIC CONTEST

1st Prize, Section A: G. Price, Melbourne, Australia; Section B: A. M. Jefferson, Auckland, N.Z. 2nd Prize, Section A: E. de Sincay, Montreux, Switzerland; Section B: P. R. Brookman, Toronto, Canada. 3rd Prize, Section A: N. A. MacDougall, Victoria, Canada; Section B: R. Whitehead, Durban,

S. Africa. Consolation Prizes: F. Kempster, Blackrock, Eire; D. Bradshaw, Ashford, Eire; H. R. Humphreys, Cairo, Egypt; S. T. Thomas, Durban, S. Africa; J. Welsh, Brisbane, Australia; F. K. MacDonald, Toronto, Canada.

## SOLUTIONS

### AUGUST 1949 SPORTS CONTEST

1st Cricket; 2nd Cycling; 3rd Swimming; 4th Lawn Tennis; 5th Motor Car Racing; 6th Motor Cycling; 7th Walking; 8th Rounders; 9th Golf; 10th Rowing.

### SEPTEMBER 1949 RAILWAY CONTEST

1. Negative conductor rail; for the return current from the motors of electric trains. 2. Telephone box; for communication with the signal box when necessary. 3. Windshield; acts as a draught screen for the enginemans when looking out. 4. Gantry; supports the signals in their correct position over the tracks. 5. Smoke plate; to protect an overhead structure from the harmful effects of smoke, etc., emitted by engines passing beneath. 6. Colour light signal; indicates whether the line to which it applies is clear or not. 7. White diamond plate; indicates to the enginemans that the line is track-circuited (or otherwise protected) and that the signal is exempt from the operation of rule 55, which requires the driver or fireman to proceed to the signal box if their train is detained at the signal. 8. Top-feed cover; houses the clack-boxes and valves through which the feed water is delivered into the boiler. 9. Lamp iron; to carry a lamp or head-code disc. 10. Smoke-box door locking handles; when tightened up, make the smoke-box door airtight as required for good steaming. 11. Shed plate; shows the code number of the shed to which the engine belongs. 12. Smoke-box saddle; supports the leading end of the boiler. 13. Driving wheel balance weight; to help counterbalance the coupling and connecting rods. 14. Mechanical lubricator; supplies oil to various moving parts. 15. Steam pipe cover; contains the pipe passing steam from the boiler into the steam chest. 16. Tail rod guide; supports the front end of the valve spindle of the inside cylinder. 17. Guard iron; these throw off from the track any obstructions which might cause derailment.



This excellent sketch by R. Francis, Crewe, was awarded 3rd Prize in the September 1949 Holiday Drawing Contest.

**The Pennine Way—**(Continued from page 64)

scheme, declaring that such a project would be a boon in linking up the National Parks. The stumbling block to the adoption of the idea is that new tracks will have to be opened, particularly along the southern section of the proposed route. In that region existing footpaths are few, and in some parts of the Peak District restrictions on the use of the open spaces by walkers have long been zealously applied by landowners.

Yet the Pennine Way may be said to exist to a big degree. There are rights of way along 180 of the 250 miles, and only 16 of the remaining 70 miles have been the subject of controversy between landowners and hikers. Thus, it is already possible to tramp from Malham, in Airedale, to Wooler, in Northumberland, using only trodden tracks along England's backbone.

Energetic walkers are striving to complete the scheme which will enable them to hike along the whole 250 miles, covering it in stages of 15-20 miles or less. The Way in its entirety would introduce many people to new scenic charms, for it would help to refute the fairly widespread notion that the Pennine region is completely sullied by towns and smoke.

**Luxury Bus Travel in South Africa—**

(Continued from page 69)

driver's seat. At the rear of the bus is a luggage compartment almost 8 ft. wide and 4 ft. high.

External lights, green at the front and red behind, indicate the height and width of the vehicle and render identification easy on the road at night. Massive front and rear bumpers are part of the design. Their utility was proved on one occasion when a Pretoria-bound bus was unable to leave Johannesburg station owing to a jammed starter. Another bus came up behind and pushed it along until the starter was freed.

In all, more than 100 of these super-saloons have been ordered by the South African Railways, at a cost of just under £7,000 each. The department offers a choice of many delightful round trips, such as that between Durban and Cape Town, via the Garden Route. The excellence of the main roads has made possible these lengthy tours, of which full advantage is taken by South Africans and overseas visitors. Small wonder that travellers prefer this service to that of the trains, and even, in many cases, to a journey by private car. In the heat of summer few cars can equal the comfort of these air-conditioned buses; only one train, the famous "Blue Train" of the Cape-Jo'burg run, is similarly equipped.

**New Meccano Models—**(Continued from page 83)

fitted on the bolts used for the purpose allow the steering to operate freely. Double Angle Strip 18 is braced by a 2½ Strip 21 fixed to the Flanged Plate 1.

Parts required to build the model Fork Lift Truck: 2 of No. 1; 14 of No. 2; 3 of No. 3; 2 of No. 4; 10 of No. 5; 1 of No. 6a; 4 of No. 8; 7 of No. 10; 9 of No. 12; 2 of No. 12a; 1 of No. 14; 1 of No. 15; 1 of No. 15b; 1 of No. 16; 1 of No. 19b; 3 of No. 22; 1 of No. 24; 4 of No. 35; 120 of No. 37; 10 of No. 37a; 10 of No. 38; 5 of No. 48a; 2 of No. 48b; 1 of No. 51; 1 of No. 52; 2 of No. 53; 4 of No. 59; 2 of No. 90; 2 of No. 90a; 2 of No. 111; 2 of No. 111a; 3 of No. 111c; 1 of No. 126; 4 of No. 126a; 1 of No. 155; 4 of No. 187; 4 of No. 188; 4 of No. 189; 6 of No. 190; 2 of No. 191; 4 of No. 192; 2 of No. 199; 2 of No. 200; 2 of No. 214; 4 of No. 215.

**SPRING BACK BINDERS FOR THE "M.M."**

There is no better way of keeping copies of the "M.M." clean and tidy than by using the spring back binder designed for the purpose. This has strong stiff backs and has the name "Meccano Magazine" in gilt on the front. It holds 12 copies, and the issues can readily be inserted or taken out. The price is 3/6 including postage.

**"A.T.C." on the Southend Line—**

(Continued from page 76)

automatic train control is very good indeed, mechanical instruments may sometimes go wrong, and perhaps during a fog at night-time there might come a rare occasion when the "A.T.C." gives a wrong indication. This of course does not often happen, but there is a possibility that it might.

Every driver to whom I have spoken about "A.T.C." liked it and agreed what a blessing it was to him in foggy weather. When you consider that during the winter time in one week the "A.T.C." makes over 60,000 correct indications of the distant signals you can well imagine what a wonderful thing is automatic train control.

**Sugar from Beet—**(Continued from page 57)

process is perhaps the most fascinating to watch. At first, the inside of the revolving drum contains a brownish substance, but gradually this turns as white as snow as the sugar is separated.

Molasses is used as a cattle food, and also is distilled into commercial alcohol for a great variety of purposes, including the manufacture of plastics. About 120,000 tons of molasses leave our sugar factories every year.

Finally, the pure refined sugar is dried, cooled and poured into bags. These are filled automatically by hopper, and after sealing are stacked in the vast air-conditioned stores of the factory. The actual time taken in the complete transformation of raw beet into granulated sugar is only about eighteen hours.

**"BRITISH RAILWAYS TO-DAY AND TO-MORROW"**

An illustrated booklet under this title that has been issued by the Railway Executive gives a brief account of our railways at the present time. The progress that has been made in the two years of nationalisation is recorded and the aims of British Railways in regard to improvements and services, stock, plant and equipment are detailed, while reference is made to many varied aspects of modern railway work.

From the booklet we can sense the importance of the railways to the life of the country. On the passenger side special attention is drawn to travel facilities of all kinds, and a wealth of interesting details are given of freight working in general and of the special measures taken to deal with heavy traffic such as the transport of coal, for home use and for export, collection and delivery methods, and warehousing and steamship services.

A particularly interesting chapter deals with railway workers and arrangements for their welfare and training. What British Railways are doing with regard to motive power and rolling stock also is dealt with, after which permanent way and stations engage attention. There are accounts of improved methods of track laying and maintenance, signalling schemes and new works generally. A list is given of named expresses and a table of mileposts in the history of British railways gives readers a summary of their growth.

With its many illustrations and a folding map, the booklet forms a compact and useful work of reference.

**A SCHOOLBOY'S EXHIBITION DEMONSTRATION**

At the Schoolboy's Exhibition at the Royal Horticultural Hall, which was open from 31st December 1949 to 14th January 1950 a large exhibit, sponsored by our advertisers Johnsons of Hendon Ltd., the photographic chemical manufacturers, showed by practical demonstrations how easy it is for boys to start Home Photography.

The process of developing films was explained and contact prints, exposed by the boys were developed on the spot. An enlarger was in operation, and after a demonstration on toning and tinting every boy present received a free copy of a book on photography.



# Fireside Fun

"What! You won't have another piece of cake, Willie? You must be suffering from loss of appetite."  
 "No, mum, just from politeness."



"Would you like me to hold your horse, sir?"  
 "No. He won't run away."  
 "I meant to hold him up, sir."

"Found a mouse yesterday in the wash house. It must have been scared stiff."  
 "Whatever do you mean?"  
 "Drowned in a bowl of starch."

"This Admiral Nelson must have been far better at remembering things than I am."  
 "What makes you say that?"  
 "Well, teacher told us that a big monument was erected to his memory in London."

"Why does it rain, mother?"  
 "To make things grow, dearie."  
 "Then what's going to grow on our house top?"

"I am going to sell this alarm clock. It's no good at all."  
 "What's wrong with it?"  
 "It never rings when I can hear it. I'm always asleep when it goes off."

"You know Jones, I don't like that fellow Brown at all. He's deceitful."  
 "How's that, Smith?"  
 "Well, yesterday he passed me without a look, and to-day he greeted me like an old friend."  
 "That was nice of him surely."  
 "Yes, but he called me Green."



"Will you get down on your hands and knees, uncle?"  
 "What on earth for?"  
 "I have to draw an elephant for my homework."

## BRAIN TEASERS SOUNDS RIDICULOUSLY EASY

A fishmonger wished to cut into two equal pieces a cube of ice measuring a foot each way. He fastened heavy weights to the ends of a piece of piano wire and laid this over the block so that the weights would pull the wire through the ice, and found that the wire cut an inch downward in an hour. How long would it be before the block was cut into two pieces?  
 S.W.C.

## A DATE PUZZLE

This year 1st February is on a Wednesday. When will it next be on Saturday, and what will be the date of the second Tuesday in February 1960?

## BIRTHDAY TALK

A few days ago a father and son were talking about their next birthday anniversaries, which will occur on the same date.  
 "When the day comes I shall have had three times as many birthdays as you," said the father.  
 "Yes," replied the son. "And five years ago you had had seven times as many."  
 How old will each be on his next birthday?

## SAME BEFORE AND AFTER

Here are the skeletons of eight words in which the first two letters, or in some cases the first three, are the same as the corresponding number of letters at the end, in the same order:

\*\*\*ur\*\*; \*\*gib\*\*;; \*\*i\*\*;; \*\*p\*\*;; \*\*y\*\*li\*\*;  
 \*\*\*o\*\*;; \*\*iat\*\*;; \*\*isat\*\*;

What are the words?



"We've called to see the old geyser."  
 "You're too late; the missus has just gone out."

## SOLUTIONS TO LAST MONTH'S PUZZLES

The diagram shows the solution to our first puzzle last month.  
 Adding 3,952 to 678 produces 4,630. The six figures required to solve our second problem actually go in three pairs, and it does not



pair is placed in the top line of the addition sum. Thus 3,678 and 952 provide another form of solution.

The ages of the married people of our third problem are 84 and 45.

The successive words of the pyramid in our fourth puzzle are: I, IS, SIT, SITE, STILE, TILERS and TOILERS.

## A NEW ASTRA MODEL



### TRAFFIC SIGNALS

A realistic working model with red, amber and green lights, working off a small torch battery. Just the thing for use with model cars, trains, etc.!

**PRICE 7/6**  
including tax

Sole patentees and manufacturers:

**ASTRA PHAROS LTD.**

239, EARLS COURT ROAD, LONDON S W 5

## HIGHSTONE UTILITIES

**Meters.** 15 v., 2½ in., m/c, 9/6; 150 v., 2 in., m/c, 10/-; 18/600 v., 2 in., m/c, D.R., 8/-; 100 m/a., 2 in., m/c, 7/6; 3.5 amp., 2 in. T.C., 5/-; 4 amp., 2½ in. T.C., in case with switch, 7/6; 20 amp., 2½ in., m/i, 9/6. Meter Movements, 2 in. size with magnet and case (500 microamp.), 2/6. Units containing two movements, 5/-. All post extra.

**Bell Transformers.** These guaranteed transformers work from any A.C. Mains, giving 3, 5, or 8 volts output at 1 amp., operate bulb, buzzer or bell. Will supply light in bedroom or larder, etc. Price 8/-, post 6d. P.F.L.I.S., 6/-.

**Ex-R.A.F. 2-valve (2-volt) Microphone Amplifiers** as used in plane inter-com., in self-contained metal case; can be used to make up a deaf aid outfit, intercommunication system, or with crystal set, complete with valves, 20/-, post 1/6. Ditto, less valves, 10/-. **Hand Microphones**, with switch in handle, and lead, 4/-. Similar instrument, moving coil, 7/6, post 6d.

**Mike Buttons** (carbon), 2/-. **Moving Coil**, 4/6; **Transformers**, 5/-. All post 4d. each.

**Soldering Irons.** Our new streamlined Iron is supplied with two interchangeable bits, one each straight and curved; 200/250 v. 50 watts, 9/-. **Standard Iron** with adjustable bit, 200/250 v., 60 watts, 9/6. **Heavy Duty Iron**, 150 watts, 12/6, all post 6d. **Crystal Sets.** Our latest Model is a real radio receiver, fitted with a permanent crystal detector, 9/6, post 6d. De Luxe Receiver in polished cabinet, 18/6, post 1/-. Spare Permanent Detectors, 2/- each. When ordered separately, 2/6, with clips and screws, 2/10, post 3d. Headphones, brand new, S. G. Brown, G.E.C., etc., 15/-, 23/-, and super-sensitive, 30/-, post 8d. **New Headphones**, 10/-. Balanced armature type (very sensitive), 12/6. Both post 8d. **New Single Earpieces**, 3/6. Bal. armature type, 4/6; ex-R.A.F. earpiece, 2/-, post 4d. **Headphones**, in good order, 4/6 and 5/6 (better quality, 7/6), all post 6d. Letters only. Money refunded if not completely satisfied.

58, New Wanstead, London E.11

Illustrated list sent on request with 1d. stamp and S.A.E.

## CONSTRUCTIONAL SCALE MODEL



READY ASSEMBLED  
**56'6"**  
Revised Price

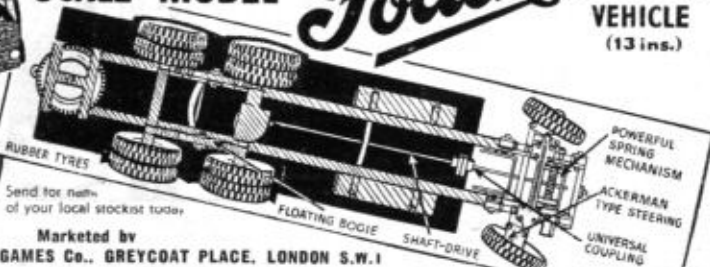

Send for name of your local stockist today.

Marketed by

ABBEY-CORINTHIAN GAMES Co., GREYCOAT PLACE, LONDON S.W.1

WANT TO SKETCH?

*Doust Art Manuals*  
WILL SHOW THE WAY

Series includes Oil Painting, Lettering, Perspective  
Detailed List available from  
**FREDERICK WARNE & CO. LTD.**  
BEDFORD COURT, BEDFORD STREET, LONDON, W.C.2

## CHEMISTRY APPARATUS



Send Stamp for COMPLETE PRICE LIST

BOOKLETS:  
"Experiments" 7d.  
"Formulas" 10d.  
"Home Chemistry" 2/3  
Post Paid

**BECK** (Scientific Dept. G), 60, High Street  
STOKE NEWINGTON, LONDON N.16

# THE FUTURE IS YOURS PREPARE FOR IT NOW

**Maximum production, on which the life of the nation rests, depends on high technical skill. This gives marvellous opportunities to young men who have acquired such knowledge and efficiency as that contained in an I.C.S. Course of Instruction.**

**THE DEMAND FOR WELL-TRAINED MEN IS URGENT AND UNLIMITED — BUT THERE IS NO WORTH-WHILE PLACE FOR THE UNTRAINED**

*If you need technical training, our advice on any matter concerning your work and your career is yours for the asking—free and without obligation. Let us send you full information regarding the subject in which you are specially interested. **DON'T DELAY.** Make **ACTION** your watchword.*

**The successful man DOES to-day what the failure INTENDS doing to-morrow. Write to us TO-DAY.**

**The I.C.S. offer Courses of Instruction in a wide range of subjects, including:**

Accountancy	Joinery
Advertising	Journalism (Free-Lance)
Aeronautical Engineering	Machine Designing
Air and Vacuum Brakes	Marine Engineering
Air-Conditioning	Mechanical Drawing
Architecture	Mechanical Engineering
Architectural Drawing	Mine Surveying
Auditing	Mining Electrical
Boilermaking	Motor Engineering
Book-keeping	Motor Mechanic
Building	Motor Vehicle Operation
Business Training	Plastics
Business Management	Quantity Surveying
Carpentry	Radio Engineering
Chemical Engineering	Radio Service Eng.
Chemistry, Org. & Inorg.	Railroad Engineering
Civil Engineering	Refrigeration
Clerk of Works	Salesmanship
Coal Mining	Sanitary Engineering
Commercial Art	Sheet-Metal Work
Concrete Engineering	Short-Story Writing
Diesel Engineering	Steam Engineering
Draughtsmanship	Structural Steelwork
(State which branch)	Surveying
Drawing Office Practice	(State which branch)
Electrical Engineering	Telegraph Engineering
Eng. Shop Practice	Television Technology
Fire Engineering	Toolmaking
Fuel Technology	Welding, Gas and Elec.
Heating and Ventilation	Woodworking Drawing
Hydraulic Engineering	Works Engineering
Hydro-Electric	Works Management
Illumination Engineering	

*And most of the Technical, Professional, Commercial, Educational and Civil Service Exams, also U.C.T.A. in salesmanship.*

*(Examination students are coached till successful.)*

**YOU MAY USE THIS COUPON**

*(Penny stamp on unsealed envelope)*

**INTERNATIONAL CORRESPONDENCE SCHOOLS LTD.**  
**Dept. 218, International Buildings, Kingsway, London W.C.2**

Please send your free booklet describing I.C.S. Courses in

Name..... Age.....

(BLOCK LETTERS PLEASE)

Address.....





# Make a model St. Paul's like this

## With one of **HOBBIES** BRITISH FRETWORK OUTFITS

Hundreds of things you can make from a Pipe Rack to St. Paul's Cathedral model. Complete kit of materials, full-size plans and instructions. All you need is a set of Hobbies Tools. Sets from 9/- and each one complete. A fascinating pleasure for your spare time.

Free illustrated lists of models and outfits on request

See the outfits at any Hobbies Branch, and all leading stores and ironmongers. Or details from Hobbies Ltd., Dept. 96, Dereham, Norfolk



Britain's new cars  
in 4 mm. scale

See the new

## MODEL CRAFT CAR PLANS

Each of these plans costs 9d. (plus 1d. postage) and includes an account of new techniques of building the models. The first of the series are:

EC101—HILLMAN MINX SALOON 1949

EC102—HUMBER HAWK SALOON 1949

EC103—SUNBEAM-TALBOT SPORTS

SALOON 1949

EC104—HUMBER SUPER SNIPE

SALOON 1949

★ Over 40 Road Transport plans in 4 mm. scale are listed in the Modelcraft 1950 List as well as coloured card cutouts, etc. There are over 600 items in the list, plans, planbooks, kits and accessories. It's a really good 'bob's worth.' 1/- post free or from your modelshop.

**MODEL CRAFT LTD.**  
77 (H), Grosvenor Road, London S.W.1

## YOU'LL BE PROUD

of the lorry you build from a  
**WILSON Kit**

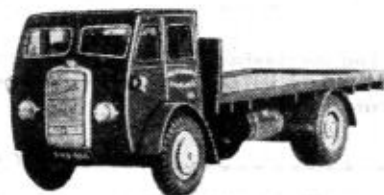

Send 1d. for lists of our 4 mm. and 7 mm. lorry kits, 24 'no-tools-to-make-'em' outfits and a host of spare parts.

Hand-built models from 7/6 a speciality

**WILSON'S LORRIES LTD.**  
Dept. M  
1, Gt. Winchester St., London E.C.2

# LOTT'S CHEMISTRY

Convert your chemistry set to a student's laboratory by easy stages.

Supplies of spare apparatus and chemicals are now available.

Ask to see them at your dealer or write to the manufacturers for correct price list, enclosing stamped addressed envelope 1d.

**LOTT'S BRICKS LTD**  
Dept. M.M.3  
**WATFORD HERTS**



**"DUNLOP  
TYRES  
-they're  
tough  
like me!"**

911/323

# Mamod

MINOR No. 2 STEAM ENGINE



The perfect miniature power-plant to drive your models

**29/5**

including Purchase Tax

This immensely popular model is fitted with highly polished seamless brass boiler 4½" long, 2" diameter red spoked brass flywheel and safety valve, beautifully finished in red, green and black, and complete with filler funnel, spirit lamp and full instructions.

**ALL MAMOD ENGINES AND WORKING MODELS FIT MECCANO AND ARE 100% GUARANTEED**

Ask your dealer to show you this famous range, or write for illustrated leaflets enclosing 1d. stamped addressed envelope to:

**MALINS (ENGINEERS) LIMITED**  
25-31, CAMDEN STREET, BIRMINGHAM 1

**BOND'S****Gauge "O" Track Control Fittings**

Brass Point Levers, 2/6 each; Brass Fork Joints tapped 10 B.A., 3/9 doz.; Brass Couplings tapped 10 B.A., 3/- doz.; Brass Horizontal Cranks, 8/6 doz.; Brass Rod Guides, 3/6 doz.; 12 volt Reversing Controller, 39/- each; 12 volt Circuit Breaker, 41/6 each; Colour Light Signals, 2 aspect, 14/8 each; Colour Light Signals, 3 aspect, 18/4 each; Colour Light Signals, 4 aspect, 22/- each; Colour Light Signals, Searchlight, 2 aspect, 15/4 each; Power Units, output 12 volts, 5 amps., £11 8s. each.

**Building Wood**

"O" Gauge Wagon Side, plank marked, 1½ in. high, 1/3 yd.; "O" Gauge Wagon Side, plank marked, 2 21/32 in. high, 2/6 yd.; "O" Gauge Coach Side, 1½ in. high, 1/6 yd.; "O" Gauge Coach Bottom Rail for glazed windows, 2/6 yd.; "O" Gauge Coach Roof to be used with bottom rail, 7/6 yd.

**Strip Wood**

1 in. x 1 in.	2½ d. yd.	1 in. x 1 in.	4d. yd.
1 in. x 1 in.	2½ d. yd.	1 in. x 1 in.	5d. yd.
1 in. x 1 in.	4d. yd.	1 in. x 1 in.	5d. yd.
1 in. x 1 in.	5d. yd.	1 in. x 1 in.	7d. yd.
1 in. x 1 in.	7d. yd.	1 in. x 1½ in.	9d. yd.
1 in. x 1 in.	8d. yd.	1 in. x 2 in.	1/2 yd.
1 in. x 2 in.	9d. yd.	1 in. x 3 in.	1/7 yd.
1 in. x 2 in.	11d. yd.	1 in. x 6 in.	2/8 yd.
1 in. x 3 in.	1/2 yd.	1 in. x ½ in.	7d. yd.
1 in. x 6 in.	2/- yd.		

All Prices plus packing and postage.

**BOND'S 1949 PRICE LIST**

This List is now available giving prices of all Model Railways, Aeroplane and Ship parts, also Materials and Tools. Price 9d.

**BOND'S O' EUSTON ROAD LTD.**

357, EUSTON ROAD, LONDON N.W.1.  
Est. 1887 Phone: EUSton 5441-2

*It's realistic*



*It's 'Plasticine'*

Made only by HARBUTT'S

Almost any type of model can faithfully be modelled in "PLASTICINE" which is so easy to handle that modifications can rapidly be made as the work proceeds. For prototypes, "mock-ups" and other uses there is no more practical medium. Long-lasting, hygienic and available in 16 attractive colours.

**HARBUTT'S PLASTICINE LTD.**  
BATHAMPTON, BATH, SOM.

*MORE than a toy!*

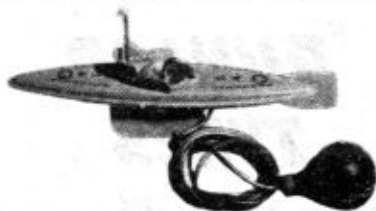
**CONTROL YOUR OWN SUBMARINE**

This is a really amazing, realistic toy. You can make it dive, surface, and travel at speed both under and above water, all by remote control. The 'Snort' Submarine is simple to work, and strongly constructed of aluminium complete with detachable periscope. Length 9 in. Price 5/11. Packing and Postage 9d. extra.

**Hamleys**  
ESTD 1849  
**HAMLEY BROTHERS LTD**

200-202, REGENT ST., LONDON W.1  
(Our only address) Telephone: REgent 3161

**Every boy can build his own MODEL RAILWAY**

BUILDING an OO Model Railway is within the scope of every boy of average intelligence and provides a thrilling way of spending the long winter evenings. ERG (Bournemouth) LTD. specialise in providing all the parts necessary for the home constructor. ERG Track Parts are the finest in the world for realism and strength. Any track formation and all types of point-work can be built cheaply and easily. For building your own rolling stock ERG "Precision" Card Parts used in conjunction with our text-book "Cardboard Rolling Stock and How to Build It" (by post only 2/9) form the ideal method. Parts are available for a wide variety of wagons, vans and coaches. Our methods give correct detail and the ease of construction is most entertaining and really astonishing. Kits are available for building your own locos, and we stock a wonderful range of accessories including such items as Signals, Building Kits, Spring Buffers and Spring Axleguards. Full details are given in The ERG Catalogue and Manual, price 2/6 post free. For those who like quick assembly of rolling stock we recommend ERG "Master-piece" Parts, the finest plastic parts on the market. Nine different models available, including Brake Van, Open Wagons, Closed Vans and Petrol Tanker, Cattle Wagon ready shortly.

Send for a copy of The ERG Catalogue and Manual (price 2s. 6d.) and "Cardboard Rolling Stock and How to Build It" (by post only 2s. 9d.) to-day and make a start on the finest hobby in the world.

**ERG (Bournemouth) LTD.**

(Dept. M.15)

529 ROUMELIA LANE, BOSCOMBE, BOURNEMOUTH  
Boscombe 33431 Trade inquiries invited

# RAWLPLUG PRODUCTS

**INDISPENSABLE  
IN THE WORKSHOP  
HANDY IN THE HOME**



**DUROFIX** The indispensable adhesive for instant use on crockery, glass, wood, metal, celluloid and the thousand and one things handled by the hobbies enthusiast. Instant drying, insulating, water-proof and heatproof. Durofix is grand for repairs to electrical, sports and leather goods. Tubes 9d. and 1 3d. Tins 2.9d. and 7 6d.



**DUROGLUE** Undiluted Animal Glue of incomparable strength. Ready for instant use for the many purposes for which an extra strong glue is needed. Wood, cloth, fabric, felt, leather and any greasable surface can be stuck with Duroglue. Tubes 6d. & 1/- Tins 2.3d. & 3.9d.



**PLASTIC WOOD** APPLIED LIKE PUTTY, DRIES LIKE WOOD. Can be cut, planed, polished and painted like wood. Will take nails and screws like wood. It does not blister, crack or decay. Rawlplug Plastic Wood is actually the best quality product of its kind on the market. Tubes 9d. Tins 2 - and 5 -.



**TILE CEMENT** Rawlplug Tile Cement is a liquid cement possessing very strong adhesive qualities. For replacing tiles to walls, floors, fireplaces, hearth, curbs, etc., in kitchens, lavatories, bathrooms, halls, bedrooms, reception rooms, etc. 2/3 per tin.



**SHARPENER** For re-sharpening Tools, Scrapers and Axes, and Garden Implements. An efficient Tool with a great number of uses. Hardwood Handle, polished and varnished with Sharpening Stone of medium grading. Use water, or a thin clear oil if stone cuts too rapidly. For cleaning stone—wash with paraffin. 2/- each.

## RAWLPLUG FIXING DEVICES AND TOOLS

Whatever your fixing problems, there's a Rawlplug device that will solve it for you—easily and quickly. Rawlplugs make neat and absolutely firm fixings in any material from plaster or brick to stone or slate, with a size for every screw from No. 3 up to 1/2" coach screws. Rawlplug Tools are easy to use and ensure a perfect hole without damage to surrounding surfaces. Other Rawlplug Devices include Rawbolts for heavy duty fixings, Rawanchors and ToggleBolts for in or hollow materials and Rawclips for instant fixing of conduits and cables to girders—a device in fact for every need. Rawlplug Fixing Devices and products can be obtained from Ironmongers, Hardware Dealers or Model Makers' Suppliers.

THE RAWLPLUG COMPANY LTD. LONDON, S.W.7.

JOHNSONS OF HENDON MANUFACTURE A POPULAR RANGE OF PHOTOGRAPHIC CHEMICALS SOLD IN SMALL AND HANDY PACKAGES UNDER THE BRAND NAME



## PACTUMS

JOHNSON PACTUMS are exceptionally useful for those amateur photographers who like to make up small quantities of solution at a time. Toners, Intensifiers and Reducers are only needed occasionally and to have the chemicals at hand in this convenient form saves time and trouble. Get a few PACTUMS of each kind and keep them ready in your dark room.

\*THE MOST POPULAR PACTUM PACKAGE IS M-Q DEVELOPER, CONTAINING ALL THE CHEMICALS REQUIRED TO MAKE 10-OZ. OF SOLUTION FOR DISH DEVELOPMENT. THIS M-Q PACTUM WILL MAKE 16-OZ. OF SOLUTION FOR USING IN A TANK.

The following packages are available:

- \*M-Q DEVELOPER (Metol-Quinol)
- COPPER INTENSIFIER for 8-oz.
- REDUCER sufficient for 8-oz.
- BLUE TONER for making 10-oz.
- SEPIA TONER to make up 8-oz.
- GREEN TONER for making 10-oz.

Ask your Dealer for Scales Brand Pactums.

JOHNSONS OF HENDON LIMITED  
LONDON N.W.4 ESTABLISHED 1743

## THE GLENBUR MODEL SUBMARINE

AS PURCHASED BY H.R.H. QUEEN MARY



THE MAJOR ATTRACTION AT THE B.I.F. OLYMPIA

BEAUTIFULLY BOXED  
100% GENUINE PERFORMANCE

**MARK I**—14 in. LONG—COMPLETE WITH GEARED WINDING STAND. IT DIVES, SURFACES OR SAILS AT PERISCOPE DEPTH. 90 FEET OF PRE-CONTROLLED DIVING PERFORMANCE.

**24/6** including tax, plus 1/6 Reg. Postage, etc.

**MARK II**—7½ in. LONG—GEARED WINDER BUILT INTO HULL, 30 FEET OF DIVING. IT IS THE IDEAL TOY FOR THE BATH OR GARDEN POND.

**12/6** including tax, plus 1/6 Reg. Postage, etc.

Order now and get one by return of post

**VAL ISHERWOOD**

The Sports Shop

Embassy Building, Formby, Lancs.

## SPARKS' DATA SHEETS

ARE NOW RECOGNISED as the Finest and Most Reliable Radio Constructional Sheets obtainable. They provide "Easy-to-Follow" Full-size Assembly and Wiring Plans of Tested and Guaranteed Designs, plus Detailed Descriptive matter which renders previous Radio experience unnecessary.

**THE "POCKET PAK" PORTABLE.** A fine little one-valve all-dry battery Set for Medium-waves. Completely self-contained except 'Phones. Fine 'Phone signals from the 'local' Stations, or greater range with a short aerial. Only 7½ x 3½ x 1½ in. Very Popular. Data/S. 2/9.

**THE "JUNIOR" ONE-VALVER.** Another all-dry battery design giving good 'Phone signals on Med. and Long-waves in any district with short aerial. 2/6. **FORTY OTHER DESIGNS AVAILABLE, SEND STAMP FOR LATEST LIST No. 38/48.** ALL COMPONENTS CAN BE SUPPLIED.

SPARKS' DATA SHEETS (MM)

9, Phoebe Road, Brockley, London S.E.4

(Phone: Lee Green 0220)

## The *Jan Allan* Mail Order Department is for YOUR service

Latest publications:

	Post Free
TRAINS IN COLOUR (9 full colour plates)	1/8
TRAINS PHOTOPIX. All Art	1/8
TRAINS ILLUSTRATED—No. 16	1/2
LET'S PAINT TRAINS (a Painting Book for all ages)	1/8
RAILWAY MODELLER—No. 2	1/8
A.B.C. BRITISH RAILWAYS LOCOS. (fully bound) Combined volume	9/-
BUSES ILLUSTRATED—No. 2	1/8
BUSES & TRAMS (Stiff cover, all Art)	9/-
MODEL PLANES ANNUAL	2/9

*Jan Allan Ltd*

33, KNOLLYS ROAD, S.W.16

## WEBLEY AIR PISTOLS

Marvellously accurate for target practice



No licence required to purchase for use on enclosed premises.

Senior Mark 1  
Junior Webley Air Rifle

Write for list. WEBLEY & SCOTT LTD.,  
87, Weaman Street, Birmingham, Eng.

### BOOKS:

Modern Locos. of S.R.	1/8
British Passenger Locos.	3/-
"Freight & Mixed Traffic Locos. Loco. Body Construction"	3/-
"Three Rail Control"	4/6
"Railway Modelling in Miniature"	10/6
Assorted Lots L.M.R., G.W.R., S.R. Loco. and Train Photos, usually 6d. each	per 1/2 doz. 1/9
<b>RAILWAY ACCESSORIES:</b>	
Super Plastic Setting Figures per set of 6	3/0
Super Plastic Sitting Figures per set of 6	4/11
Scale Water Crane	3/11
Station Lamps, 3 v.	2/9
Screw 20 v. Motors, fit Hornby Locos.	1/2
<b>ELECTRIC MOTORS:</b>	
Reversing Motor, 4-6 volt D.C. (usually 15/-)	7/6
Postage extra. "00" or "0" Paris List 3d. per post.	

TYLDESLEY & HOLBROOK (M.E.A.),  
109, DEANS GATE, MANCHESTER 3

## FIND SATISFACTION IN A RADIO HOBBY



With a D.5 coil you can build this crystal set, and one to three valve sets. The best coil for beginners. From all radio component dealers. Issued with four 5/- simple radio circuits.

THE DOUGLAS COIL Co.  
BRINKLOW • RUGBY

## Overhaul Watches & Clocks Yourself

Not a toy, the Home Watch and Clock Repair Outfit is a collection of precision jeweller's instruments. Includes watchmaker's magnifying eyeglass, finest watch tweezers, watch and clock screwdrivers, oilers, clock brush, watch and clock oil, plus explanatory book in simple language with blueprints. In container, 12/9 incl.

Fully Comprehensive Outfit includes everything above, plus jeweller's rouge, dial rejuvenator, luminous compounds, watch jewels, full instructions. Price 21/- S. E. Bolster (Dept. B), 5a, Station Parade, Ashford, Middx.

### "0" NEW "SKINLEY" BLUEPRINTS "00"

S.R. "Devon Belle" stock: P.55, 3rd class Brake Pullman, No. 54, 1s. 9d.; P.56, 1st class Pullman "Iolanthe," 1s. 9d.; P. 57, Pullman Observation Tail Coach, 1s. 9d.; 171, L.N.E. 0-6-0 Goods Locomotive, class "J15" (latest condition), No. 5367, 2s.; 211, L.N.E. (Ex. N.E.) Electric 0-4-4-0 Shunting locomotive No. 6480, class ES1, 2s.; 324, S.R. (L.S.W.) 0-6-0 Goods Locomotive, No. 0395, class 2s.; 302, S.R. (Ex. S.E.C.) 0-6-0 Saddle Tank, No. 1685, class "S." 1s. 9d. Stave gauge required.

JOHN E. SKINLEY, 132, High St., Southend-on-Sea, Essex



## STAMP ADVERTISEMENTS

(See also pages 88 and 90)

## FREE—4 diff. BASUTOLAND

The above scarce stamps will be given free to all genuine applicants for our famous ONE PENNY APPROVAL BOOKLETS OF BRIT, COLONIALS. These Booklets abound with JUBILEES, PEACE, CORONATIONS, SILVER WEDDINGS and U.P.U. as well as the latest K.G. VI stamps. Many Bargains as usual. N.B.—Enclose 2d. stamp for Postage. S. FENLEY LTD., 250, Charninster Rd., Bournemouth

## 55 BRITISH COLONIALS FREE 55

Magnificent packet 55 different (no British stamps) includes these fine UNUSED.—Large Cayman Islands, large Kenya, overprinted stamps from Malta, Pakistan and Burma. All free if you send 4d. stamps to cover post and sorting, and request my discount approvals.

THIS IS A SPECIAL ADVERTISING GIFT FOR COLLECTORS IN GT. BRITAIN AND S. AFRICA ONLY  
H. PEARSON, 61, DULVERTON RD., HUISLIP, MIDDLESEX

FREE STAMPS ALL DIFFERENT  
100

including Jet Bomber, Skymaster plane, modern Battleship, Steam Locomotive and many other Pictorials. Request Discount Approvals enclosing 4d. for postage, etc. A. HUGHES, 34, LOCHALINE STREET, LONDON W.6

**FREE FOR THE ASKING** Any four of these beautiful mint pictorials Belgium, Train; French-India, Idol; Bolivia, Battle; Hungary, Reconstruction; Romania, Chariot; Tokelau Is., 1st Issue; S. Marino, View; China, Air; Trieste, Air. Request Appvls. 2½d. postage. James Tudge, Horspath (M1) Oxford

**Foreign Stamps** 100 different 1/-; 200 2/6; 500 diff. 5/-; 1,000 mixed 5/-; 50 diff. either China, Austria, Hungary, Denmark, Italy, India, France, Germany, U.S.A., Pictorials, Norway, Sweden, Dutch or Br. Colonial 1/-; 100 2/6. Illustrated list 1d. HAND, ROSEBERY ROAD, EPSOM

## 30 SUPERB EMPIRE FREE

Including Falkland Islands pictorial (whales' jaw-bones strange design), obsolete Gold Coast, scarce Ceylon Independence and other valuable stamps. Ask to see approvals and send 3d. postage. ROSTON (S), 106, St. Dunstons Rd., London W.6

## SUPER GIFT FREE!

NEW ISSUES, OBSOLETE COMMEMORATIVES, PICTORIAL PACKET. This wonderful packet is free to all requesting bargain discount approvals. J. STONE (MM), 264, Meadow Lane, ALFRETON, Derby

BEAUTIFUL PACKET OF MINT  
AIRMAIL STAMPS

Usually sold at 1/6, FREE to all those requesting approvals and enclosing 2½d. stamp. JOHN H. ABEL 3, ALDER CLOSE, STURMINSTER NEWTON, DORSET

WILMSLOW MODEL COMPANY  
WATER LANE, WILMSLOW, CHESHIRE

Your mail order by return of post.

We have a tip-top selection of model railway and aircraft kits and accessories. Railway kits in "00" and "0" gauges. Ships kits, model racing car kits. Diesel and Petrol Engines. The largest stock of modelling materials in the north.

Send 3d. stamp for new 8-page list.

## Crystal Set Kits 15/-

Complete with instructions. Endless entertainment and no further expense. Ideal for School or College. Lightweight Headphones 15/-. All post free. W. Buckle (Dept. M.) 77, Horringer Rd., Bury St, Edmunds

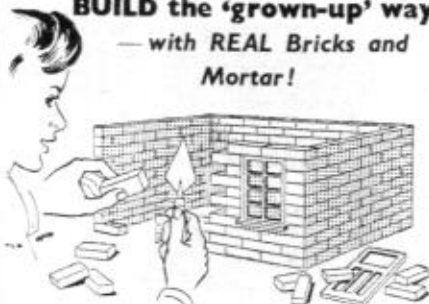
BUILD the 'grown-up' way  
— with REAL Bricks and  
Mortar!

A 'BRICKPLAYER' KIT provides all the necessary materials for constructing models of houses, garages, railway stations, etc. from real plans.

No. 3 Outfit contains bricks of various sizes, metal windows, door frames, roofing and glazing materials and cement; also plans, etc. Complete for 23/10

Post &amp; Pckg. 1/2.

Larger sizes and accessories available. Illustrated leaflet post free.

**Selfridges**

Toys—Third Floor

SELFRIDGES LTD., LONDON, W.1.

MAYfair 1234

STUDY AT HOME FOR  
MATRICULATION

Wolsey Hall (Est. 1884) will coach you by post for London Matric.; School Cert.; Gen. Cert. in Educn.; H.S.C.; Lond. B.Sc.; Teachers' exams., etc. Tuition continued free if you fail; low fees, instalments. PROSPECTUS FREE from Director of Studies, Dept. GK1, WOLSEY HALL, OXFORD

## Bargain Parcel—Aircraft Instruments

Precision equipment that cost hundreds of pounds to manufacture SUPPLIED AT A FRACTION OF COST. Containing a wealth of precision parts suitable for modelmakers, etc. such as pinions, gears, bearings, pivots, gyro-wheels, meter movements, etc.

Send details of your requirements and we will supply instruments to suit.

WHILE THEY LAST 6 of any type for 7/6 plus 1/4 post & pkg. Write for our list of interesting items of all types.

WILFLO PRODUCTS, 216-222, Gorbais St., Glasgow C.5

## CIGARETTE CARD COLLECTORS

Send 3d. for our list of 500 series, compare our prices with others. 100 cards 2/9. Albums for 200 cards 1/9.

Dept. "M," E.H.W. LTD., 42, Victoria St., London S.W.1

Learn Shorthand by 1st Mar. (1 hour's study nightly). 1st lesson 2½d. stamp. Duttons (Dept. M0), 92, Gt. Russell St., W.C.1



This Signal Box is one of the many models made from a No. 2 Bayko Set

ASK YOUR DEALER FOR DETAILS OF

# BAYKO

the Original Plastic BUILDING SETS

PRICES:

No. 0 ..	13/9	No. 0x ..	6/10
No. 1 ..	20/7	No. 1x ..	13/9
No. 2 ..	34/4	No. 2x ..	20/7
No. 3 ..	55/-		

PLIMPTON ENGINEERING Co. Ltd.  
GIBRALTAR ROW, LIVERPOOL 3

## CIGARETTE CARDS

**BOYS!** Be wise don't buy before seeing our 1950 List of Sets and Mixtures at Keenest prices—12 pages of bargains—Price 6d. post free. Comprises over 1,000 different sets in fine condition Assortments, New Albums, from 6d. upwards and 1/- Beginner's Packets. We will include **FREE** Packet Cigarette Cards with first 50 lists sent out to readers of this Magazine.

J. H. DAVIS & CO. (Dept. M.M.)

18, Glifden Road, Brentford, Middlesex (Ealing 6822)

Have you **JUNEERO ANNUAL** Price 1/- got you yet? from 1/2 from Juneero Dealers everywhere. Post free 1/2 from: **JUNEERO LTD., Stirling Corner, Boreham Wood, Herts.**

35 mm. films. All descriptions from 6/- Baers, 176, Wardour St., London W.1. Hire Programmes 10/-

## READERS' SALES AND WANTS

Frog 1.75 c.c. Petrol Engine, used twice, 55/-; Episode as new, £3; Stamp Collection (cat. £12), would separate, offers; S.G. Simplified Catalogues 1943 and 1946, 6/- and 9/-; "M.M.s" March 1945-November 1947 (four missing), 6/-;—S. W. Hockey, "Fowkes," Marston Magna, Yeovil, Somerset.

Over 300 copies "Dandy," "Beano" and "Film Fun"; 16 Dinky Toy Aeroplanes and 16 in. Triang Speedboat. All good condition. Best offers secure.—Seth, "Woolacombe," Court Drive, Hillingdon, Middlesex.

Large collection of Meccano, including Clockwork Motor and many Gears, £7/10/-.—D. F. Robinson, 14, Dalmeny Avenue, Norbury, London S.W.16.

Complete Gauge 0 Hornby Railway Set in excellent condition, comprising Three Locomotives; 19 pieces Passenger and Goods Rolling Stock; 21 pieces ancillary equipment, i.e., Station, Engine Shed, Signals, Buffers, Tunnels, Bridges, Crossings, etc. and 63 ft. Straight and Curved Track, £13/10/-;—Sykes, 28, Brockley View, London S.E.23.

# MECCANO MAGAZINE

Registered at the G.P.O., London, for transmission by Canadian Magazine Post.

EDITORIAL AND ADVERTISING OFFICES:  
LIVERPOOL 13, ENGLAND.

Telegrams: "Meccano, Liverpool."

**Readers' Sales and Wants.** Private advertisements (i.e., not trade) are charged 1d. per word, minimum 1/-, Cash with order. Readers' advertisements are published as soon as possible; inclusion in the first issue after receiving them cannot be guaranteed.

0 Gauge Bassett-Lowke scale models "George The Fifth," "Duke of York" clockwork Locomotives; L.N.E.R. and L.M.S. Coaches, including 12-wheel Dining Car, new, unscratched condition.—Wheeler, 51, St. Margaret's Road, London S.E.4.

70 Dinky Toys and Supertoys, perfect condition (few exceptions), value over £7; best offer over £8. "Radio Fun" May 1944-July 1949 (two missing); "Hotspurs" November 1947-August 1949. Offers.—Tresise, 227, Earlim Road, Norwich.

Gauge 0 Bassett-Lowke 2-6-0 Steam Loco.; Hornby Coaches; Track (S.S. Perm. Way); Accessories; £15. S.A.E. details.—Wyde, "Eastergate," Glentrammon Road, Farborough, Kent.

"M.M.s" and Stamp Magazines, July 1941 to July 1949, few missing; good condition; offers.—F. E. Morgan, 67, Ty-isal Park Avenue, Kisca, Mon.

"M.M.s" March 1947 to December 1949 (January and February 1948 missing). In very good condition. Offers to—K. Langton, 58, High Street, Rochester, Nr. Uttoxeter, Staffs.

"M.M.s" January 1947-March 1949. Good condition; offers.—Livesley, 10, Beulah Avenue, Morecambe.

Hornby Train Set: Two Locomotives; Two Coaches; Eight Trucks; Three Points; Rails; Engine Shed; Water Tower; Signals and Accessories; 20 Dinky Toys, £6 or nearest.—"Bayko" Building Set No. 2. 15/-;—"B.O.P.s" May 1943 to May 1949 (three missing), 50/-;—"The World's Railways";—"Triumphs of Engineering";—"How it is Made";—"Britain's Wonderful Fighting Forces";—"Britain's Wonderful Air Force";—"Britain's Modern Army";—"Britain's Merchant Navy"; 5/- each.—M. Wallace, 6, Ainderby Road, Northallerton, Yorks.

Bargain! Unused Baby Brownie Camera, 13/-.—Finner, Eastville, Albert Road, Cork, Eire.

Blue/Gold Meccano up to No. 7, fairly cheap. Write—Finner, Eastville, Albert Road, Cork, Eire.

35 Dinky Toys including Two Dinky Supertoys (Foden Lorry and Bulldozer). Price £2/15/-; all in excellent condition.—Barron, 10, Douglas Street, Nairn, Scotland.

78 "M.M.s" 1942-48; majority excellent. Best offer over 25/-.—Canning, 18, Hazel Bank, King's Norton 20 Foreign Coins, 12/8, carriage paid.—J. Ronie, Jnr., 74, Gilmore Road, Edinburgh.

Dinky Toys and Supertoys; reduced prices and in good condition; S.A.E. for list.—Lloyd, New Place, Ewelme, Oxon.

### WANTS

Two Hornby heavy Clockwork Locomotives, any condition; also Track and Rolling Stock. Full particulars.—Millar, C.P.O.s Mess, H.M.S. Myngs, c/o G.P.O., Portsmouth.

Urgently: Hornby-Dublo Electric short Rails; good price paid. Also Hornby-Dublo No. 2 Transformer.—Drew, 218, Old Bedford Road, Luton.

"M.M." for September 1948. State price.—J. Alexander, 6, Wilson Grove, Heysham, Lancashire.

"M.M.s" 1923, 1924, 1929, 1932. State price.—J. A. Gomes, 154, Perry Road, Bandra, Bombay, India.

Required urgently: "M.M." January 1948, good condition.—Clark, 30, Rosehill Road, Burnley, Lancs.

# DINKY BUILDER

The  
Building Toy  
for Younger Folks



Simplicity is the keynote of this fascinating building system. With Dinky Builder hinged plates and rods, the youngest children can build all kinds of models with the greatest ease—Furniture, Buildings, Windmills, Wheel Toys and scores of others.

The parts are beautifully enamelled in blue and yellow. They can be used over and over again. Nuts and bolts are not used in this system.

Two Complete Dinky Builder Outfits  
are available—No. 1 and No. 2

For prices see current list

MADE IN ENGLAND BY MECCANO LTD.

More fun with your  
**MECCANO**  
Outfit



## MECCANO GEARS OUTFIT "A"

This Gears Outfit "A" has been specially designed for owners of the smaller standard Meccano Outfits, which do not include gears.

Used in conjunction with any Outfit from No. 2 to No. 6, it will enable you to drive your models through gears just as real engineers do, instead of having to be content with pulleys and belts. You will find it quite simple to fit into your Meccano models various mechanisms of the type that are described and illustrated in the Book of Instructions.

Ask your  
Dealer to  
show you  
this new  
Meccano  
Gears  
Outfit

MADE IN ENGLAND BY MECCANO LTD.